

# CITY of NOVI CITY COUNCIL

**Agenda Item D  
June 17, 2019**

**SUBJECT: Approval to award the purchase of a Kardex Remstar Lektriever Vertical Carousel from Kardex Remstar, LLC under the Sourcwell Contract in the amount of \$41,659.58.**

**SUBMITTING DEPARTMENT:** City Clerk

**CITY MANAGER APPROVAL:** *PR*

<b>EXPENDITURE REQUIRED</b>	<b>\$41,659.58</b>
<b>AMOUNT BUDGETED</b>	<b>\$41,700 (FY 2019-2020 Budget)</b>
<b>APPROPRIATION REQUIRED</b>	<b>\$0</b>
<b>LINE ITEM NUMBER</b>	<b>101-215.00-982.045</b>

**BACKGROUND INFORMATION:**

The City Clerk's Office utilizes a mechanical rolodex to store voter registration cards. While the voter files are also available digitally, State Law requires we maintain the physical cards while the voter is active and for five years after the voter's record is cancelled. As far as we can determine, the current rolodex is from 1986 and the company is no longer in business. There are no longer any technicians that will service the rolodex if it needs repairs. This unit is budgeted in Fiscal Year 19-20, so the purchase will not be made until after July 1, 2019.

**RECOMMENDED ACTION:** Approve the purchase of a Kardex Remstar Lektriever Vertical Carousel from Kardex Remstar, LLC under the Sourcwell Contract in the amount of \$41,659.58.

# City of Novi

Attn: Cortney Hanson



Kardex Remstar, LLC  
Kyle Vail  
41 Eisenhower Drive  
Westbrook, ME 04092  
815-520-9980

*This document contains information that is proprietary to Kardex Remstar, and the customer identified herein. Reproduction and distribution of this document is restricted for exclusive use by the above named entitled. The information contained herein is subject to change without notice, and shall supersede information in similar documents produced for the above named entity. Warranties governing the suitability and contents, whether expressed or implied, are limited to use of this document in the manner in which it is intended, as described herein. Kardex Remstar makes no warranties for consequential or incidental damages connected with the furnishing and use of this material.*

**Table of Contents**

---

**AUTOMATION & STORAGE SOLUTIONS – WHAT CAN WE DO FOR YOU? 3**

**LEKTRIEVER VERTICAL CAROUSEL EQUIPMENT SPECIFICATIONS 7**

STANDARD FEATURES 7

STANDARD SAFETY FEATURES 8

LEKTRIEVER CONTROL OPTIONS 9

OPTIONAL FEATURES 10

**WORK COUNTER OPTIONS 11**

**MODEL 120 CARRIER OPTIONS 12**

MULTIPURPOSE CARRIER 12

INTERMEDIATE SHELVES FOR MULTIPURPOSE CARRIER 12

**SCOPE & SUPPLY 13**

TECHNICAL SPECIFICATIONS 13

PRICING QUOTE/PROPOSAL ID #: JL-061318-01 14

**APPENDICES 15**

APPENDIX A: UNIT LAYOUT 15

APPENDIX B: WARRANTY INFORMATION 16

APPENDIX C: NJPA CONTRACT INFORMATION 18

**Automation & Storage Solutions – What Can We Do For You?**

**The Principle**

Paper records, files, stationery, CD/DVD, credit cards, library, and X-ray; light industrial applications, sample vials, artifacts, valuables collectors' items, guns, sports equipment, check books, certificates and licenses... we understand that companies have to contend with an ever-widening range of media. That's why we've developed solutions to suit any of these applications, which will save space, improve security and productivity, comply with the latest legislation, deliver a greener office environment and save you money.



The Lektriever Vertical Carousel is designed with shelves or drawers that rotate up or down via the shortest path, automatically delivering stored items to an operator at an ergonomically positioned pick window. Each unit is compatible with an entire suite of software and controls or can be used as a standalone solution.

The Lektriever Vertical Carousel is equipped with both personnel and product photocells for maximum safety. Stored goods are protected from unauthorized access by a lockable door. Security can be further increased with optional inventory management software providing password protection and transaction tracking for single or multiple items.

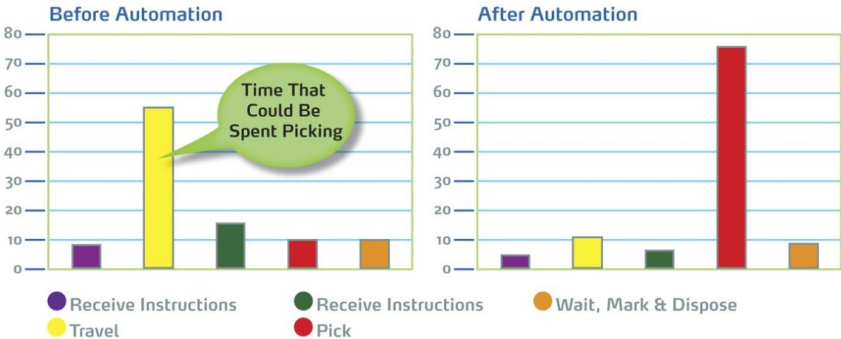

## Reduced Labor Costs

Automated storage and picking solutions allow operators to perform at higher levels. By delivering items directly to the operator, travel and search time commonly associated with shelving is drastically reduced. This allows the operator to spend more time picking, increasing overall productivity.

Due to reduced travel and search time in an automated storage and picking solution, picking from shelving that required several workers, often only requires one worker to handle the same volume. Automated storage and picking solutions are a great option when labor is scarce or unreliable. Typically, labor can be reduced by 2/3 while maintaining pick volume.

More often, facilities are choosing to maintain current labor levels when implementing automated storage and picking solutions to increase picking productivity – resulting in higher picking capacities without additional labor.

- Automate Material Processing Flow & Reduced Product Handling
- Ergonomic Bulk Handling
- Improved System Flexibility
- Accurate Inventory Control

## Increased Retrieval Speeds

- By introducing automation in filing and storage, the Lektriever enables tasks to be carried out from one seated or standing location, without the need to move away from the workstation.
- Time and motion studies clearly show that productivity gains of over 100% are experienced by users of Lektrievers, when compared to manual systems such as drawer and lateral cabinets as well as static and mobile shelving.
- The Lektriever Vertical Carousel requires less training time as there is no need to memorize locations.
- Position lights provide increased accuracy by directing the operator to the location to pick or put, increasing picking speed and accuracy.
- Decreased employee fatigue by eliminating bending to pick up items from floor level shelves or reaching for top shelf items.



## Increased Space Utilization

- By taking advantage of cubic volume and not square area, the Lektriever automated vertical carousel optimizes floor space.
- The unit can be built right up to ceiling height, and when considered at the design stages of a building, can even be built to go through a number of floors while maintaining the same footprint.
- Compared to other solutions, it is one of the most efficient in terms of linear storage metres per square foot of floor space – up to twice as efficient as drawer and lateral cabinets.

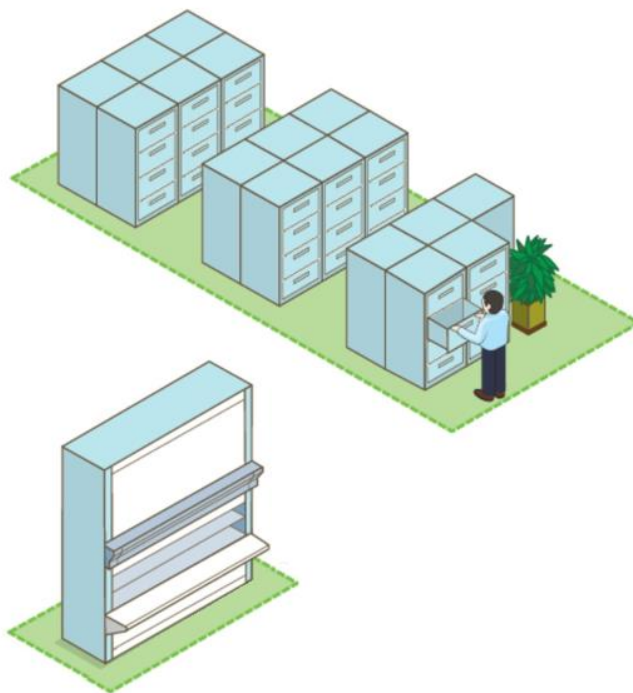

## Increased Control

- Reduced supervisory needs as employees have a small, well-defined work area and do not have to move between several locations.
- Storage activities can be computer driven to optimize picking and allow batch order processing.
- The use of log-on log-off passwords in conjunction with an automatic security door defines who is operating each piece of equipment and facilitates tracking and reports.
- Improved Replenishment Operations
- Software-Enhanced Reporting Capabilities
- Improved SKU Management (Slotting)
- Emergency hand crank gives you access to your stored material in case of a power outage.

## Increased Ergonomics

- The Lektriever Vertical Carousel's ergonomic design eliminates bending and reaching for stored items, the product is delivered to the operator.
- Work counter height can be designed to fit your end user's ideal ergonomic height.

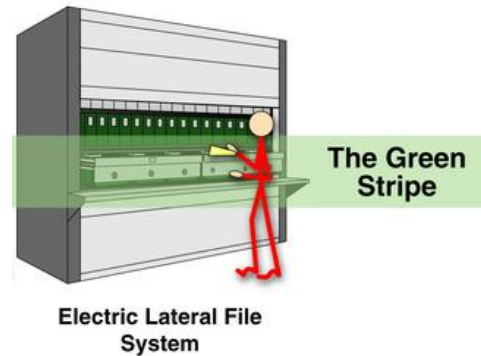
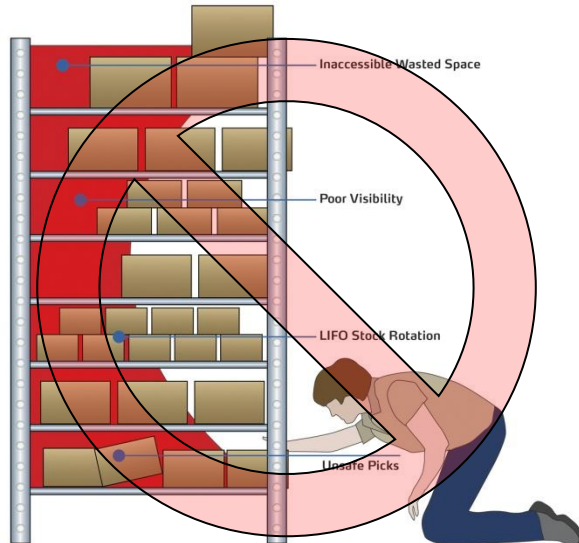

## Modularity & Flexibility – A System That Can Grow With You

- Intermediate shelves can be added or adjusted as needed to fit your demands.
- The end frame panels can be split into multiple sections allowing height to be easily added or subtracted to meet future requirements.

## Aesthetics

- Fully enclosed painted steel unit dramatically improves aesthetics over conventional shelving.
- Can be color-coordinated to match desired customer colors.

### Standard Features

#### Mechanical Door

As standard our units include a self-counterbalancing, lockable dual panel sliding door, easy to open and close and protects stored goods from dust and unauthorized access. In addition the upper and lower panels of the access opening act as a mechanical security switches, in case of contact, the security circuit is activated affecting an intermediate stop of the unit operation.



#### Emergency Hand Crank

A method of manually rotating the carriers (without power if necessary) is available by use of a hand crank. If during hand crank operation power is returned to the unit, it shall remain non-operational by means of a micro switch interrupt caused by the hand crank attachment.



## Standard Safety Features

All units include a safety systems witch continually monitors the proper operation of the unit. Maximum safety stopping distance is +/-0.59". The Lektriever ELF Includes:

- Two Emergency Stop Button's
- Mechanical Safety Bars (an integral part of the door assembly)
- Infra-red Photocells (2 sets)
- Safety Switches for Lower Front Access Panel, Hand Crank, Opening & Overheating Motor
- Micro Switch Interrupts To:
  1. Prevent unit operation if the door is not completely open
  2. Prevent unit operation if maintenance access panel is not secure
  3. Prevent unit operation if hand crank is in place
- Safety Light Curtain: the access opening is secured by a safety light curtain. This will prevent a unit start when items are not properly stored in the unit, such as handing of product of pull out type carrier or drawer.
- Emergency Service Switch: The emergency service switch is used to operate the unit if there is a failure on the electronic control/keyboard, until the failure is corrected.

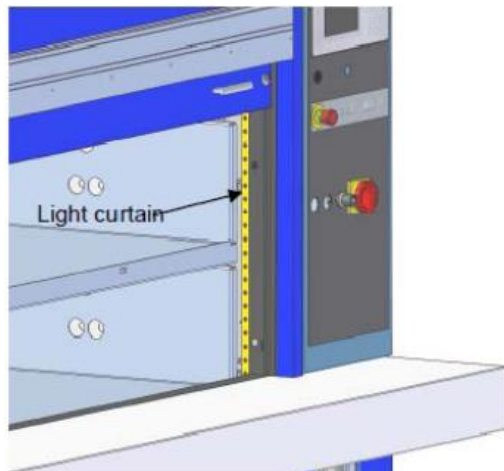

### Safety Light Curtain

Both left hand and right hand sides of the access opening area feature a safety light curtain that brings the drive to a standstill immediately if anything or anyone should break the light curtain. The light curtain also prevents the stored goods from being damaged if they happen to protrude out of the storage space.

## Lektriever Control Options

### T-O Keyboard in Work Counter

The T-0 control offers:

- Up & Down Keys for Manual rotation (carrier Selection)
- 3-Digit LED Shelf Level Display
- Numeric Keypad for Carrier
- Selection via Shortest Route
- Programmable Carrier Offset
- Start/Restart, Stop Interrupt Buttons
- System Error Indication
- Firmware Revision Indication

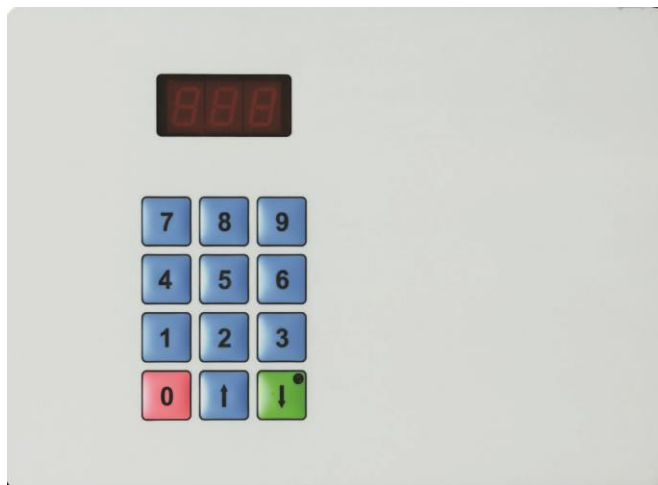

## Optional Features

### Front Light

An optional front light can be ordered with the Lektriever Vertical Carousel. This front light illuminates the access point so that users can easily see to retrieve what they are looking for. This front light can be helpful when the unit is placed in a room with dim lighting.



### Imbalance Indication

When a unit is ordered with the optional imbalance indicator an imbalance situation can be detected/recorded by the frequency inverter and transferred to the control via Digital-I/O where the signal is evaluated. The vertical movement in state of imbalance is stopped at the next carrier and a message is displayed.

**Work Counter Options**

---

The Lektriever Vertical Carousel storage system offers a multitude of work counter options.

Fixed standing position of 39.4”H



**Multipurpose Carrier**

A universal design allowing lateral, multi-tier or standard tray filing applications. Multipurpose Carriers accept dividers on 1" centers, distance rails, additional shelves, etc. and are designed to allow reconfiguration for other applications without removal or replacement of the carrier.

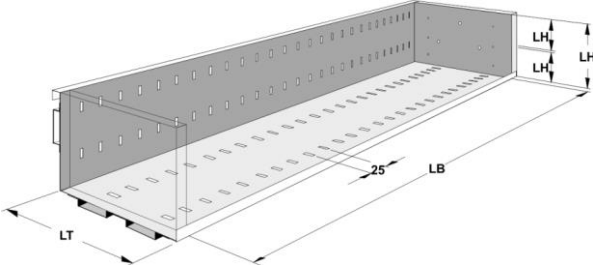

**Intermediate Shelves For Multipurpose Carrier**

Optional intermediate shelves can be added to the multipurpose carrier if required to create a dual level carrier to increase the overall storage capacity of the Lektrievier Vertical Carousel. Clear shelf heights vary with carrier pitch and number of shelves chosen, please see your unit specification sheet for exact sizes.

Intermediate shelf with bottom reinforcement

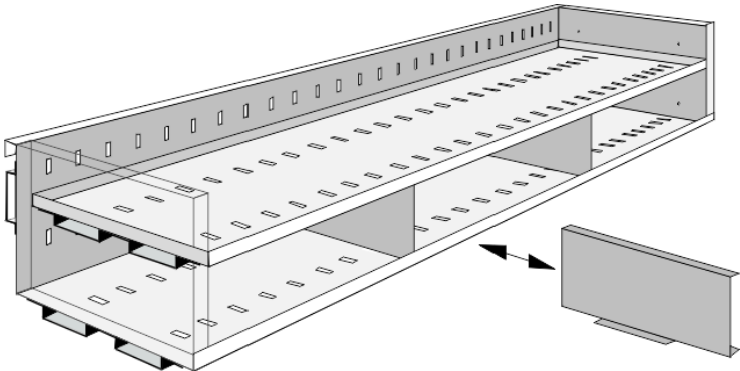

### Technical Specifications

City of Novi, City Clerk Kardex Remstar Lektriever® ELF									
Equipment Specifications									
<b>Overall Unit Specifications:</b>									
Base Unit includes lockable bi-parting door (unless automatic door has been chosen), dust cover/top, all safety circuits, safety light curtain, emergency stop left & right side, touch bars (upper and lower), motor, manual handcrank, electronics and TUV label.									
Quantity of Carousels	: 1								
Model Number	: <b>120-1013N</b>								
Overall Unit Width	: 71.26 inches (1810 mm)								
Overall Unit Depth (without posting board)	: 45.47 inches (1155 mm)								
Work Counter (posting board) Depth	: 11.82 in. (300 mm)								
Overall Unit Height	: 88.59 inches (2250 mm)								
Unit Weight Empty (includes carrier weight)	: 2503 lbs.								
Unit Weight - Fully Loaded	: 5467 lbs.								
Max. Total Load (including carrier dead weight)	: 4070 kg (8,973 lb)								
Top Tolerance at Balanced Load	: +/- 15mm (.059")								
Minimum Ceiling Height: 89.38 inches (2270 mm)									
*Units can be placed side by side, or back to back. When a unit is to be installed through a ceiling or in a niche, free space of approximately 1.2" (30 mm) is required all around the unit.									
Average Floor Load (based on Unit weight-fully loaded)	: <b>1.69 lbs./in² (242.96 lbs./ft²)</b>								
Supporting contact surface	: <b>125.24 in² / 808 cm²</b>								
Dynamic Unit Weight (Newtons)	: <b>32,841</b>								
Dynamic Floor Load Bearing Capacity	: <b>2.28 lbs./in² (328.32 lbs./ft²)</b>								
Maximum Imbalance Load	: 300 kg (660 lbs)								
Cycle Speed	: 7.0 inches / second								
Average Access Time (1/4 carousel revolution)	: 4.6 seconds								
Color Selection (Endframes)	: Standard-Light Gray								
Color Selection (Panels)	: Standard-Light Gray								
Noise Level	: < 60 db(A)								
<b>Access Opening Information:</b>									
Work Counter Type & Height	: Standing 39.4 in. (1000mm)								
Work Counter Finish	: Light Gray								
Door Type	: Standard Manual Bi-parting Door w/Keylock								
Opening Clear Height	: 19.41 in. (493mm)								
Access Lighting	: Full Width Light Above Access Opening								
<b>Power &amp; Controls:</b>									
Power Supply	: 110 Volt /1-/60 Hz								
Drive, Gear Motor	: AC - Gear Motor - 1.5 kva								
AMP Draw	: 16 AMP								
Average Power Consumption	: 2.0 KVA								
Control	: TO Control								
Controller Location	: Work Counter								
E-Stop	: Included Left & Right Side of Access Opening								
Emergency Service Switch	: Included								
Computer Interface	: No								
Imbalance Detection	: Imbalance Detection Module Included								
<b>Standard Safety Features</b>									
Expanded Error Indicator	Upper and Lower Mechanical Safety Bars (Doors)								
Safety Light Curtain	Safety Switches for Lower Front Access Panel and Hand Crank Opening								
E-Stop Left & Right Side	Emergency Service Switch								
<b>Standard Features included in Base unit</b>									
Electronics Located in the Bottom Access Panel	Top Dust Cover								
Hand Crank for Installation of Carriers and Service	Access for Service from Front								
<b>Additional Features and Options</b>									
(192) Gliding Rollers For Small Tray Removal Included									
<b>Carrier Specifications:</b>									
		Specifications Per Carrier							
Carousel's Carrier Configuration	Qty	Clear Height	Clear Width	Clear Depth	Max. Capacity	*Avg. Capacity	LFI Per Carrier	Total LFI Per Carrier Style	
Multipurpose Carrier	10	11.85	57.09	16.14	330 lbs.	330 lbs.	57	570	
Additional Shelves for 2 levels (1/carrier)	8	5.43	56.61	16.10	144 lbs. per level	144 lbs. per level			
Useful height / drawer									
Clear width / drawer									
Clear depth / drawer									
# of Drawers / Carrier									
Avg. Capacity / Drawer									
LFI Per Carrier									
							N/A		
<b>Total Linear Filing Inches (LFI) for 1 unit(s)</b>									
: 570		Multimedia Carriers/Drawers are not included in Total LFI calculation							
(Does not include carriers with additional shelves or drawers)		*Avg. capacity is based on a unit configured with one carrier type.							

**Model 120-1013N (1810) .....\$ 24,379.58**

- Qty. 1 Unit, Overall unit size 71.26”W x 88.59”H x 45.47”D (57.29” w/work counter)
- Unit includes (10) Multipurpose Carriers, 11.85”H x 57.09”W x 16.14”D
  - 8 of 10 carriers to include (1) additional reinforced shelf to split carrier into two levels of 5.43”H clear
- Includes (96) TR-85, 8x5 car trays for storage on the split level carriers
- Front Light
- Fixed Standing Light Gray Work Counter
- T0 Control in Work Counter with Index Cardholder
- Imbalance Detection Module
- E-Service Switch & E-Stop Button Left & Right of Access Opening
- Two (2) Years Parts and Labor Factory Warranty

**Estimated Freight (Westbrook, ME to Customer Location)..... \$ 3,500.00**

**Mechanical Equipment Installation ..... \$ 9,280.00**

- Includes Two (2) Year Semi-Annual PM Contract, Visits @ 6, 12 & 18 months
- Power must be present or supplied by the customer.

**Existing Unit Removal and Disposal ..... \$ 4,500.00**

- Remove Existing White System. Includes disassembly, move via elevator to first floor and then removed off site and disposed of.

**Project Total ..... \$ 41,659.58**

**Exceptions/Limitations/Disclaimers/Clarifications**

- Mechanical and electrical installation to be non-union unless otherwise specified.
- Delay of work due to site obstructions, lack of electrical power, etc. could result in additional charges.
- Delivery in approximately 120 days ARO

### Appendix A: Unit Layout

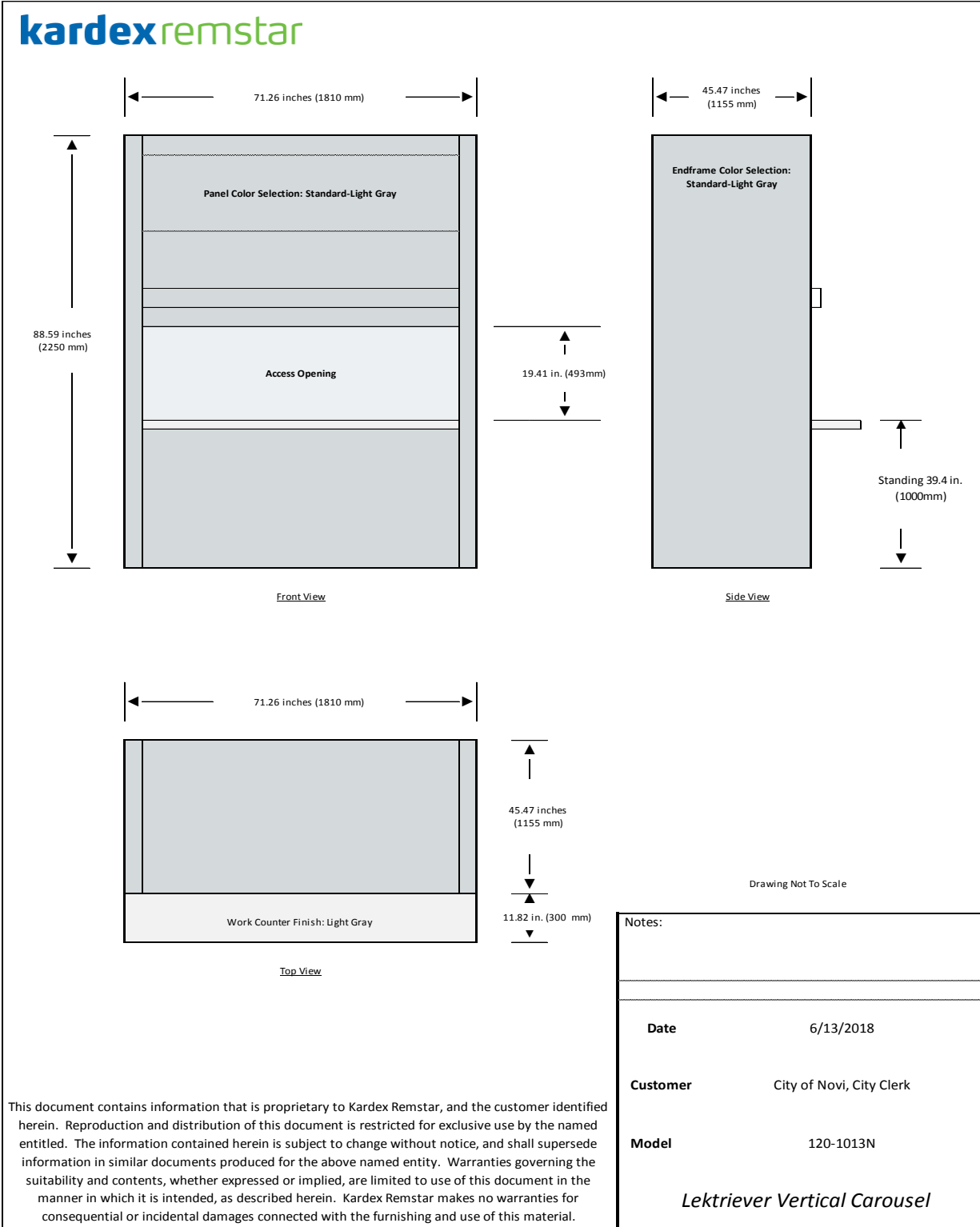



## Appendix B: Warranty Information

### Warranty Statement –Lektriever Vertical Carousel

Kardex Remstar warrants all new Lektriever Electric Lateral Files to be free from defects caused by substandard material or inferior workmanship. This liability is limited to the obligation to repair, or at Kardex Remstar's discretion, replace without charge any part found to be defective under normal wear and tear within two (2) years from the commencement of this warranty. The warranty period begins upon completion of installation, or within four (4) weeks of the originally scheduled delivery date of equipment, whichever date is first.

For an additional cost, Kardex Remstar offers an optional Extended Warranty on its vertical carousels. Lektriever Electric Lateral Files are eligible for up to five (5) total years of warranty (the standard two years plus three additional years of coverage). The extended warranty period is subject to the same terms covering inclusions, exclusions, invalidations, payment policies, and geographical scope that exist for the standard warranty period.

Kardex Remstar warranty coverage, both standard and extended, is contingent upon the complete performance of scheduled maintenance on the equipment. Scheduled maintenance must be performed at minimum biannually, including during the first two years, by Kardex Remstar Certified Technicians, and performance of that scheduled maintenance must be reported to Kardex Remstar promptly via your local Kardex Remstar dealer. For more information on extended warranty coverage, including the associated costs, please contact your Kardex Remstar dealer.

### Lifetime Motor Warranty

Under the terms of the warranty, Kardex Remstar will replace free of charge any vertical carousel drive motor that fails while using standard maintenance and operating conditions for the life of the carousel providing scheduled maintenance is completed biannually. To confirm that your machine meets these requirements, contact Kardex Remstar's Warranty Administrator.

### Extent of Coverage

This warranty pertains to all Kardex Remstar Lektriever Electric Lateral Files. This warranty is limited to the original purchaser of equipment and is not transferable.

### Invalidation

1. This warranty will be invalidated if any of the following occur:
2. The Kardex Remstar unit is operated outside the recommended parameters as specified in the operations manual and on the machine data plate.
3. The unit is modified in any way which is not authorized in writing by Kardex Remstar prior to the modification.
4. Scheduled maintenance is not carried out at least biannually (or as recommended by Kardex Remstar for individual application) by Kardex Remstar Certified Technicians.
5. 4. Any installation, service, relocation, or other work is performed by anyone other than Kardex Remstar Certified Technicians.\*
6. Scheduled Maintenance Checklist is not reported to Kardex Remstar within thirty (30) days of performance of scheduled maintenance.

7. The conveyor chains of the vertical carousel are not re-tightened within five (5) days of machine loading.

## Exclusions

The following are not covered under the scope of the warranty:

1. The replacement of fuses.
2. The replacement of fluorescent bulbs.
3. Ancillary equipment supplied by others, or damage caused by such equipment.
4. The replacement of lost, damaged, or broken keys.
5. Routine adjustments (e.g., photocells, microswitches, re-initialization of controls, belt/chain tensioning).
6. Damage or intermittent failure caused by connection to incorrect power supplies.
7. Damage caused by improper storage of materials within equipment.
8. Removal of obstructions internal or external to the unit (e.g., conveyors, dropped ceilings, computer floors).
1. Repairs necessitated by abuse, negligent care, deliberate damage, accident, fire, flood, power supply surges, riots, war, or acts of God.
2. Consequential damages.\*\*

## Geographical Scope

This warranty covers all 48 contiguous states, and Washington, D.C., and Canada. In Alaska, Hawaii, Puerto Rico and other worldwide locations, the warranty is the same, except that the warrantee is responsible for payment of the service technician's time and travel expenses to and from the nearest Kardex Remstar authorized service center, the cost of parts shipment and handling, and associated duties and customs fees.

The warranty is expressly in lieu of all other warranties, expressed or implied (including but not limited to the implied warranties of merchantability or fitness) and constitutes all of Kardex Remstar's liability in respect to its equipment.

\*While Kardex Remstar maintenance training classes are available to its customers for a fee, scheduled maintenance, if performed by Customer technicians for the purpose of maintaining the standard or extended warranty, must be done under the direct supervision of a Kardex Remstar Certified Dealer Technician. Timely filing of the scheduled maintenance online form to Kardex Remstar is in this case the responsibility of the supervising Dealer, not the Customer. The supervising Dealer is responsible for costs associated with any repairs that result from improper, incomplete, or untimely scheduled maintenance, for the balance of the warranty period.

\*\*Some states do not allow the exclusion or limitation of incidental or consequential damage, so the above limitation or exclusion may not apply to the warranty. This warranty gives you specific legal rights and you may also have other rights which may vary from state to state. To know what your legal rights are in your state, consult your statutes.

## Appendix C: NJPA CONTRACT INFORMATION

Contract#: 040215-KRS  
 Category: Storage  
 Description: Storage and Retrieval Products  
 Contract Date: 06/16/2015 - 06/16/2019



Please make orders out to:

Kardex Remstar, LLC  
 Attn: NJPA Order Entry  
 41 Eisenhower Drive  
 Westbrook, ME 04092

Phone: 740-350-3665, Fax: 740-236-1525

\*Please reference contract #040215-KRS on all PO's.

CUSTOMER INFORMATION FOR ORDERING ACTIVITIES:

1. **Minimum Order:** \$50.00 Net
2. **Discounts from List Price** (Discounts are applied to the product list price (before freight or any applicable taxes are added):

Product Type – Storage Products (Non-Automated): Office Products, High Density Mobile, L & T Shelving and Drawers, Warehouse Shelving, Logic Shelving, Workbench and Shop Equipment, Technical Workstations, & Lockers	Applicable Discount: Order Value \$0 - \$50,000- 36% Discount Order Value \$50,001 and up - 40% Discount
Product Type – Automated Equipment: <del>Lektriever, Magamat</del> Vertical Carousel, Shuttle XP Vertical Lift	Applicable Discount: 39.25% Discount
Product Type – Automated Equipment: Horizontal Carousel – 10%	Applicable Discount: 10% Discount

3. **Payment Terms:** Net 30 days,
  - a. Prompt Payment Discount Of 1% -10 days (Discount Not Applicable On CC Orders)
4. **Credit Card accepted:** 2.75% handling fee per transaction will be assessed.
5. **Time of Delivery:**
  - a. Storage Products: 30-45 days after receipt of order unless otherwise noted
  - b. Automated Equipment: 90-120 days after receipt of order unless otherwise noted
6. **Freight Not Included.** Please contact for a freight quote.
  - a. Storage Products FOB: Dickson, TN,
  - b. Automated Equipment FOB: Westbrook, ME
7. **Payment Address:** Kardex Remstar, LLC, TD Banknorth, N.A., P.O. Box 9540, Portland, ME 04112
8. **Maintenance and Repair:** Contact For Pricing.
9. **Installation:**
  - a. Automated equipment will require installation by a factory certified technician, please contact us for an installation quote for your area.
  - b. Most non-automated storage products within this catalog can be assembled by the end user. If professional assembly is required as denoted by product (High Density Mobile Product) please contact us for an installation quote by an authorized installer in your area.
10. **Repair Parts:** Contact For Pricing.
11. **Service and Distribution Points:** Contact Kardex Remstar LLC, at 800-639-5805 for authorized sales and service agent | closest to you.
12. **Participating Agents (Dealers):** Contact Kardex Remstar LLC, at 800-639-5805 for authorized sales and service agent closest to you.
13. **Reconfiguration and Relocations:** Contact For Pricing.

**Contract # 040215-KRS**

**Contract Date: 6/16/15 – 6/16-19**

**DUNS 00-255-5654**

**Federal ID #27-384-6558**

**Storage & Retrieval Products Contract**

All orders against Kardex Remstar, LLC NJPA Contract are to be made out to Kardex Remstar, LLC as shown below:

Please make orders out to:

*Kardex Remstar, LLC  
Attn: NJPA Order Entry  
41 Eisenhower Drive  
Westbrook, ME 04092*

*\*Please reference contract #040215-KRS on all PO's.*

## **SCOPE OF WORK**

City of Novi - MI

### **1. PROJECT DATA:**

TITLE: Purchase and Install two (1) each Lektriever

BUILDING/FACILITY: City of Novi, City Clerk

PROJECT DURATION: 100-120 days

### **2. GENERAL SCOPE:**

The Contractor shall provide all supervision, labor, materials and equipment to remove and dispose existing unit and install one (1) new Lektriever to complete this requirement. The contractor shall perform all work outlined at City of Novi, City Clerk Office. The end user is responsible for providing electrical power to the unit. The contractor will provide final electrical hookup connections from the unit motor to the electrical disconnect.

### **3. DETAILED REQUIREMENTS (Lektriever):**

- Quantity: One (1) new Lektriever.
- Unit must provide a manual drive crank capable of moving the carriers in case of electric outage for easy access to content within the unit.
- Unit will come with an fixed standing Work Counter at 39.4 inches tall
- Unit must hold up to 80,000 voter registration cards.
- Overall size of each unit is 88.59"H (+/- 1")x 71.26"W (+/- 1") X 45.47"D (57" Including Work Counter) (+/- 1")
- 10 Multipurpose carriers.
  - 2 carriers with no intermitted shelves with clear height of 11.85" inches
  - 8 carriers with additional shelves (2 levels per carrier) with clear heights of 5.43" inches
  - Carriers to Include voter registration trays to accommodate for 80,000 cards
- Computer Interface – Up and Down keys for manual rotation (carrier selection), 3-digit LED shelf level display, Numeric key pad for carrier selection by shortest route, Programmable carrier offset, Start/restart, stop interrupt buttons, System error indicator. Key board to be mounted into right front exterior of unit.
- The unit will have an bi-parting security door with an integrated key lock.
- Model shall have self- balancing design such that unit will not jam, tilt or skew, or otherwise become inoperable due to heavy shelves, empty shelves or uneven loading.
- The unit shall have an automatic on/off interior task lighting integrated into the unit.

- The unit shall be self-contained and not require any building modifications to install (i.e. subfloor). Vendor shall be responsible to insure fit, form, and function of the file system including operator access within this room while maximizing capacity in LFI. The unit shall allow entry and exit access, and adequate access to the transaction counter of the unit.
- Materials – This high density vertical system shall be of high quality steel construction with an automotive grade painted finish.
- Electrical – Unit to plug into existing 110 volt wall outlet or hard wired into the outlet.
- Colors- Standard color or colors of light gray.

**DETAILED VENDOR REQUIREMENTS:**

- Contractor services shall be offered through an office that has a 24-hour turn-around time and must be assured and guaranteed on all requests for service. The installation and service must be performed by local factory trained and authorized qualified individuals.
- Contractor must include Preventive Maintenance Services every 6 months for the duration of the 2 year warranty period.
- The contractor must ensure the equipment complies with DIN EN 15095 “Power-operated mobile racking and shelving, carousels and storage lifts” and has been tested and certified by TÜV (Technical Observation & Control), a USA NRTL and a Canadian CB.
- Factory must be certified ISO 9001.
- Manufacture must be certified ISO 14001.
- Workmanship – All workmanship shall comply with standard trade practices. The contractor shall provide qualified factory certified personnel, equipment, and services required to install and test unit and any software.
- Training - Contractor shall provide initial training to government system administrator, upon setup and training materials.
- Documentation – The contractor shall provide complete documentation, all manuals, drawings and schematics of installed equipment. The contractor shall provide all necessary information and software documentation, so that the government can program and repair the system independent of the contractor, after the government inspects, accepts and takes ownership of the equipment.
- Cleanup – The contractor is responsible for cleaning up the area and to return it to the condition it was found. Any damages to the facility will be repaired by the contractor at their expense.
- Warranty – The contractor shall guarantee all workmanship, warranty all equipment, software and installation for a minimum period of 2 year.

**End of Scope of Work**

## Michigan Legal References

### State Agencies:

Mich. Comp. Laws § 18.1261(2017). Solicitation, award, amendment, cancellation, and appeal of state contracts; preferences and goals; powers and duties of department; disclosure of records

(7) The department may enter into a cooperative purchasing agreement with 1 or more other states or public entities for the purchase of goods, including, but not limited to, recycled goods, and services necessary for state programs.

### Local Governments:

Mich. Comp. Laws § 124.504 (2017). Joint exercise of powers; agencies; powers

Sec. 4. A public agency of this state may exercise jointly with any other public agency of this state, with a public agency of any other state of the United States, with a public agency of Canada, or with any public agency of the United States government any power, privilege, or authority that the agencies share in common and that each might exercise separately.

### School Districts:

Mich. Comp. Laws § 380.11a (4) (2017). General powers school districts; classification; general rights, powers, and duties; agreements or cooperative arrangements; school board, governance, adoption of bylaws, elections; operation of libraries, museums, or community recreational facilities; scholarship programs

(4) A general powers school district may enter into agreements, contracts, or other cooperative arrangements with other entities, public or private, including, but not limited to, another school district or an intermediate school district, or join organizations as part of performing the functions of the school district. An agreement, contract, or other cooperative arrangement that is entered into under this act is not required to comply with the provisions of the urban cooperation act of 1967, 1967 (Ex Sess) PA 7, MCL 124.501 to 124.512, as provided under section 503 of that act, MCL 124.503.

### About Sourcewell:

Sourcewell is a service cooperative created by the Minnesota legislature as a local unit of government. Minn. Const. art. XII, sec. 3. As a public corporation and agency, Sourcewell is governed by local elected municipal officials and school board members. Minn. Stat. § 123A.21 Subd. 4 (2017). Under its enabling statute, Sourcewell is explicitly authorized to provide cooperative purchasing services to eligible members. Id. at Subd. 7(23).

Sourcewell follows the competitive contracting law process to solicit, evaluate and award cooperative purchasing contracts for goods and services. Sourcewell cooperative purchasing contracts are made available through the joint exercise of powers law to member agencies. Minn. Stat. § 471.59 (2017). Membership in Sourcewell is available for all eligible state and local governments, education, higher education and nonprofit entities across North America. § 123A.21 at Subd. 3.

