



**CITY OF NOVI CITY COUNCIL
DECEMBER 11, 2023**

SUBJECT: Consideration of approval to purchase one (1) 2025 International Single-axle RDS Truck from Tri-county International through the State of Michigan MiDeal cooperative purchasing contract; and upfits to be completed by Truck and Trailer Specialties through the City of Rochester Hills RFP contract, in the amount of \$300,787.02.

SUBMITTING DEPARTMENT: Department of Public Works, Fleet & Field Operations Divisions

EXPENDITURE REQUIRED	\$ 300,787.02
AMOUNT BUDGETED	\$ 300,788.00
APPROPRIATION REQUIRED	\$ 0
LINE ITEM NUMBER	101-441.30-984.039

BACKGROUND INFORMATION:

One single-axle dump truck with a front plow, underbody scraper, and wing blade was budgeted for fiscal year 2023-24. This purchase replaces an existing 2010 heavy-duty truck (#601), used for winter maintenance and hauling aggregate. The vehicle specifications enhance service to the community by allowing operators to pre-wet salt, which speeds up activation and reduces the amount of salt scattered from the road (estimated to be as much as 40% without pre-wetting). In addition, the unit is equipped with a stainless-steel radius dump box to resist corrosion, a seven-foot wing plow (estimated to clear wide subdivisions streets up to 30% quicker than trucks not outfitted with this technology), and a computer system to automatically adjust salt and liquid application rates based on ground speed and pavement and air temperatures. These specifications conform to the standardization of the snow fleet and require no additional operator training. The estimated delivery for the truck is November 2025.

RECOMMENDED ACTION: Approval to purchase one (1) 2025 International Single-axle RDS Truck from Tri-county International through the State of Michigan MiDeal cooperative

purchasing contract; and upfits to be completed by Truck and Trailer Specialties through the City of Rochester Hills RFP contract, in the amount of \$300,787.02.

Monday, October 9, 2023

Mike Rhatigan
City of Novi
45175 W 10 Mile Rd.
Novi MI 48375-3024

Thank you for your interest in International trucks! As you are aware our industry continues to face unprecedented supply chain and production issues and this has impacted both our truck allocation and our ability to deliver ordered trucks in a timely manner. We deeply apologize for the inconvenience this has caused for your organization to schedule and budget for equipment purchases. At this time we are unable to accept PO s, deposits, or other forms of order securement until we receive additional information from our brand partner on the production outlook for 2024. We believe this information will be coming sometime soon in the fourth quarter of 2023. Until that time we will be able to continue to provide specs and tentative pricing on demand with the following qualifications:

- All specifications are subject to change prior to production based on our ability to source the requested components.
- All quoted pricing is subject to change prior to production based on internally published model year price guidelines, destination fees, and commodity or other surcharges which may change at any time.
- Your specification quote is not a slot or production promise to be built. We can take your info at this time to add to a list of interested parties. Once we have the ability to slot your order we will be in touch to re-confirm specs, pricing, and timing to solidify your intent to order.

Thank you again for your interest and if you have any questions feel free to reach me at any time.

TRI COUNTY INTL TRUCKS
JeremyKast

Prepared For:
City of Novi
Mike Rhatigan
45175 W 10 Mile Rd.
Novi, MI 48375-3024
(248)735 - 5656
Reference ID: MiDEAL HV607

Presented By:
TRI COUNTY INTL TRUCKS
Jeremy Kast
3001 E HIGH ST
JACKSON MI 49203
(517)783-2721

Tri County International Trucks, Inc./State of Michigan DTMB Contract 071B6600122, Specification #3958 0170D for a new 2025 MY International Truck Chassis per this proposal. Pricing includes all user specified option equipment costs and available discounts in effect as of date listed. Please note that the afforded pricing includes a 1% fee paid to the state of Michigan as required under this contract. Additional surcharge requirements as issued by the manufacturer may be applicable in the future.

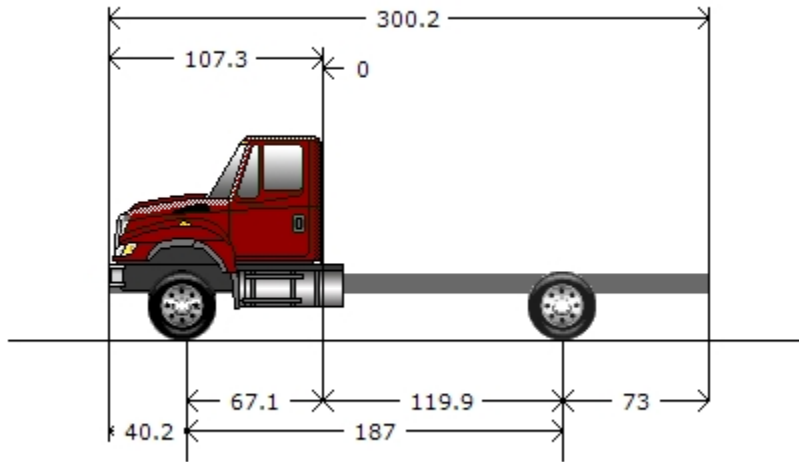

Model Profile
2025 HV607 SBA (HV607)

AXLE CONFIG:	4X2
MISSION:	Requested GVWR: 44000. Calc. GVWR: 44000. Calc. GCWR: 80000 Calc. Start / Grade Ability: 38.01% / 2.90% @ 55 MPH Calc. Geared Speed: 68.6 MPH
DIMENSION:	Wheelbase: 187.00, CA: 119.90, Axle to Frame: 73.00
ENGINE, DIESEL:	{Cummins L9 330} EPA 2024, 330HP @ 2200 RPM, 1000 lb-ft Torque @ 1200 RPM, 2200 RPM Governed Speed, 330 Peak HP (Max)
TRANSMISSION, AUTOMATIC:	{Allison 3500 RDS} 6th Generation Controls, Wide Ratio, 6-Speed with Double Overdrive, with PTO Provision, Less Retarder, Includes Oil Level Sensor, with 80,000-lb GVW and GCW Max, On/Off Highway
CLUTCH:	Omit Item (Clutch & Control)
AXLE, FRONT NON-DRIVING:	{Meritor MFS-18-133A} Wide Track, I-Beam Type, 18,000-lb Capacity
AXLE, REAR, SINGLE:	{Meritor RS-26-185} Single Reduction, 26,000-lb Capacity, Driver Controlled Locking Differential, R Wheel Ends Gear Ratio: 6.14
CAB:	Conventional, Day Cab
TIRE, FRONT:	(2) 315/80R22.5 Load Range L XZU-S2 (MICHELIN), 488 rev/mile, 65 MPH, All-Position
TIRE, REAR:	(4) 12R22.5 Load Range H G622 RSD (GOODYEAR), 482 rev/mile, 75 MPH, Drive
SUSPENSION, REAR, SINGLE:	31,000-lb Capacity, Vari-Rate Springs, with 4500-lb Capacity Auxiliary Multileaf Springs
PAINT:	Cab schematic 100WL Location 1: 2303, Red (Std) Chassis schematic N/A

<u>Code</u>	<u>Description</u>	<u>F/R Wt</u> (lbs)	<u>Tot Wt</u> (lbs)
HV60700	Base Chassis, Model HV607 SBA with 187.00 Wheelbase, 119.90 CA, and 73.00 Axle to Frame.	6136/3644	9780

AXLE CONFIGURATION

1ANA	AXLE CONFIGURATION { Navistar } 4x2	-40/-95	-135
------	-------------------------------------	---------	------

Notes

: Pricing may change if axle configuration is changed.

ENGINE

12EYX	ENGINE, DIESEL { Cummins L9 330 } EPA 2024, 330HP @ 2200 RPM, 1000 lb-ft Torque @ 1200 RPM, 2200 RPM Governed Speed, 330 Peak HP (Max)	583/-19	564
12VJS	EMISSION, CALENDAR YEAR { Cummins L9 } EPA, OBD and GHG Certified for Calendar Year 2024	0/0	0
12XCS	CARB EMISSION WARR COMPLIANCE Does Not Comply with CARB Emission Warranty	0/0	0
12WZE	CARB IDLE COMPLIANCE Does Not Comply with California Clean Air Idle Regulations	0/0	0
12WVG	EPA IDLE COMPLIANCE Low NOx Idle Engine, Complies with EPA Clean Air Regulations; Includes "Certified Clean Idle" Decal on Hood	0/0	0
12UWZ	RADIATOR Aluminum, Cross Flow, Front to Back System, 1228 SqIn, with 1167 SqIn Charge Air Cooler, Includes In-Tank Oil Cooler	23/-5	18
	<u>Includes</u> : DEAERATION SYSTEM with Surge Tank : HOSE CLAMPS, RADIATOR HOSES Gates Shrink Band Type; Thermoplastic Coolant Hose Clamps : RADIATOR HOSES Premium, Rubber		
12THT	FAN DRIVE { Horton Drivemaster } Two-Speed Type, Direct Drive, with Residual Torque Device for Disengaged Fan Speed	0/0	0
	<u>Includes</u> : FAN Nylon		
12VAL	AIR CLEANER Dual Element, with Integral Snow Valve and In-Cab Control	6/0	6
12703	ANTI-FREEZE Red, Extended Life Coolant; To -40 Degrees F/ -40 Degrees C, Freeze Protection	0/0	0
12VYP	ENGINE CONTROL, REMOTE MOUNTED No Provision for Remote Mounted Engine Control	0/0	0
12851	PTO EFFECTS, ENGINE FRONT Less PTO Unit, Includes Adapter Plate on Engine Front Mounted	10/0	10
12926	RADIATOR HOSES Silicone; Molded	0/0	0
12VXT	THROTTLE, HAND CONTROL Engine Speed Control; Electronic, Stationary, Variable Speed; Mounted on Steering Wheel	0/0	0

TRANSMISSION

<u>Code</u>	<u>Description</u>	<u>F/R</u>	<u>Wt (lbs)</u>	<u>Tot Wt (lbs)</u>
13BDR	TRANSMISSION, AUTOMATIC {Allison 3500 RDS} 6th Generation Controls, Wide Ratio, 6-Speed with Double Overdrive, with PTO Provision, Less Retarder, Includes Oil Level Sensor, with 80,000-lb GVW and GCW Max, On/Off Highway	222/61		283
13WYH	TRANSMISSION TCM LOCATION Located Inside Cab	0/0		0
13WUC	ALLISON SPARE INPUT/OUTPUT for Rugged Duty Series (RDS) and Regional Haul Series (RHS), General Purpose Trucks, Construction, Package Number 223	0/0		0
13WVV	NEUTRAL AT STOP Allison Transmission Shifts to Neutral When Service Brake is Depressed and Vehicle is at Stop; Remains in Neutral Until Service Brake is Released	0/0		0
13XAM	PTO LOCATION Dual, Customer Intends to Install PTO at Left and/or Right Side of Transmission	0/0		0
13WYU	SHIFT CONTROL PARAMETERS {Allison} 3000 or 4000 Series Transmissions, Performance Programming	0/0		0
13WLP	TRANSMISSION OIL Synthetic; 29 thru 42 Pints	0/0		0
13WET	TRANSMISSION SHIFT CONTROL Column Mounted Stalk Shifter, Not for Use with Allison 1000 & 2000 Series Transmission	1/0		1

CLUTCH

11001	CLUTCH Omit Item (Clutch & Control)	0/0		0
-------	-------------------------------------	-----	--	---

REAR AXLES, SUSPENSIONS

14ASA	AXLE, REAR, SINGLE {Meritor RS-26-185} Single Reduction, 26,000-lb Capacity, Driver Controlled Locking Differential, R Wheel Ends . Gear Ratio: 6.14 <u>Notes</u> : Axle Lead Time is 60 Days	0/290		290
14SAL	SUSPENSION, REAR, SINGLE 31,000-lb Capacity, Vari-Rate Springs, with 4500-lb Capacity Auxiliary Multileaf Springs	0/177		177

FRONT AXLES

2ARZ	AXLE, FRONT NON-DRIVING {Meritor MFS-18-133A} Wide Track, I-Beam Type, 18,000-lb Capacity	186/0		186
------	---	-------	--	-----

FRONT SUSPENSIONS

3ADG	SUSPENSION, FRONT, SPRING Parabolic Taper Leaf, Shackle Type, 18,000-lb Capacity, with Shock Absorbers	44/0		44
------	--	------	--	----

CABS, COWLS, BODIES

16030	CAB Conventional, Day Cab	0/0		0
16ZBT	ACCESS, CAB Steel, Driver & Passenger Sides, Two Steps per Door, for use with Day Cab and Extended Cab	0/0		0
16BAM	AIR CONDITIONER with Integral Heater and Defroster	0/0		0

Code	Description	F/R Wt Tot Wt	
		(lbs)	(lbs)
16WBY	ARM REST, RIGHT, DRIVER SEAT	3/0	3
16VKK	CAB INTERIOR TRIM Diamond, for Day Cab	6/1	7
	<u>Includes</u> : CONSOLE, OVERHEAD Molded Plastic with Dual Storage Pockets, Retainer Nets and CB Radio Pocket; Located Above Driver and Passenger : DOME LIGHT, CAB Door Activated and Push On-Off at Light Lens, Timed Theater Dimming, Reading Lights; Integral to Overhead Console, Center Mounted : SUN VISOR (3) Padded Vinyl; 2 Moveable (Front-to-Side) Primary Visors, Driver Side with Vanity Mirror and Toll Ticket Strap, plus 1 Auxiliary Visor (Front Only), Driver Side		
16WSK	CAB REAR SUSPENSION Air Bag Type	0/0	0
16WLS	FRESH AIR FILTER Attached to Air Intake Cover on Cowl Tray in Front of Windshield Under Hood	0/0	0
16GED	GAUGE CLUSTER Base Level; English with English Electronic Speedometer	0/0	0
	<u>Includes</u> : GAUGE CLUSTER DISPLAY: Base Level (3" Monochromatic Display), Premium Level (5" LCD Color Display); Odometer, Voltmeter, Diagnostic Messages, Gear Indicator, Trip Odometer, Total Engine Hours, Trip Hours, MPG, Distance to Empty/Refill for : GAUGE CLUSTER Speedometer, Tachometer, Engine Coolant Temp, Fuel Gauge, DEF Gauge, Oil Pressure Gauge, Primary and Secondary Air Pressure : WARNING SYSTEM Low Fuel, Low DEF, Low Oil Pressure, High Engine Coolant Temp, Low Battery Voltage (Visual and Audible), Low Air Pressure (Primary and Secondary)		
16HHE	GAUGE, AIR CLEANER RESTRICTION {Filter-Minder} Mounted in Instrument Panel	2/0	2
16HGH	GAUGE, OIL TEMP, AUTO TRANS for Allison Transmission	1/0	1
16SEE	GRAB HANDLE, EXTERIOR Chrome, Towel Bar Type, with Anti-Slip Rubber Inserts, for Cab Entry Mounted Left Side at B-Pillar	3/0	3
16975	HEATER HOSES Silicone	0/0	0
16WHJ	HOSE CLAMPS, HEATER HOSE {Breeze} Belleville Washer Type	0/0	0
16XJP	INSTRUMENT PANEL Wing Panel	0/0	0
16HKT	IP CLUSTER DISPLAY On Board Diagnostics Display of Fault Codes in Gauge Cluster	0/0	0
16SNR	MIRRORS (2) C-Loop, Power Adjust, Heated, LED Clearance Lights, Bright Heads and Arms, 7.5" x 14" Flat Glass, Includes 7.5" x 7" Convex Mirrors, for 102" Load Width	0/0	0
	<u>Notes</u> : Mirror Dimensions are Rounded to the Nearest 0.5"		
16VLV	MONITOR, TIRE PRESSURE Omit	-10/-1	-11
16JNV	SEAT, DRIVER {National 2000} Air Suspension, High Back with Integral Headrest, Cloth, Isolator, 1 Chamber Lumbar, 2 Position Front Cushion Adjust, -3 to +14 Degree Back Angle Adjust	1/0	1

<u>Code</u>	<u>Description</u>	<u>F/R Wt</u> (lbs)	<u>Tot Wt</u> (lbs)
16SMM	SEAT, PASSENGER {National} Non Suspension, High Back, Fixed Back, Integral Headrest, Cloth	16/7	23
16XWD	SUNSHADE, EXTERIOR Aerodynamic, Painted Roof Color, with Integral Clearance/Marker Lights	15/2	17
16WJU	WINDOW, POWER (2) and Power Door Locks, Left and Right Doors, Includes Express Down Feature	0/0	0
16VSL	WINDSHIELD Heated, Single Piece	0/0	0
FRAMES			
1CAJ	FRAME RAILS Heat Treated Alloy Steel (120,000 PSI Yield); 10.866" x 3.622" x 0.437" (276.0mm x 92.0mm x 11.1mm); 456.0" (11582mm) Maximum OAL	160/422	582
1LLK	BUMPER, FRONT Omit Item	-91/16	-75
1WDU	CROSSMEMBER, FRONT for Hydraulic Pump, Mounting Flange to Accommodate Pump	42/3	45
1WDS	FRAME EXTENSION, FRONT Integral; 20" In Front of Grille	137/-32	105
1570	TOW HOOK, FRONT (2) Frame Mounted	8/0	8
1572	TOW HOOK, REAR (2)	0/10	10
1WGR	WHEELBASE RANGE 138" (350cm) Through and Including 187" (475cm)	74/-74	0
BRAKES			
4091	BRAKE SYSTEM, AIR Dual System for Straight Truck Applications <u>Includes</u> : BRAKE LINES Color and Size Coded Nylon : DRAIN VALVE Twist-Type : GAUGE, AIR PRESSURE (2) Air 1 and Air 2 Gauges; Located in Instrument Cluster : PARKING BRAKE CONTROL Yellow Knob, Located on Instrument Panel : PARKING BRAKE VALVE For Truck : QUICK RELEASE VALVE On Rear Axle for Spring Brake Release: 1 for 4x2, 2 for 6x4 : SPRING BRAKE MODULATOR VALVE R-7 for 4x2, SR-7 with relay valve for 6x4/8x6	0/0	0
4AZA	AIR BRAKE ABS {Bendix AntiLock Brake System} 4-Channel (4 Sensor/4 Modulator) Full Vehicle Wheel Control System	0/0	0
4GBM	BRAKE, PARKING Manual Push-Pull Pneumatic Parking Brake	1/0	1
4XDT	BRAKES, FRONT {Meritor 16.5X6 Q-PLUS CAST} Air S-Cam Type, Cast Spider, Fabricated Shoe, Double Anchor Pin, Size 16.5" X 6", 23,000-lb Capacity	33/0	33
4EXV	BRAKE CHAMBERS, FRONT AXLE {Bendix} 24 SqIn	4/0	4
4LAA	SLACK ADJUSTERS, FRONT {Haldex} Automatic	14/0	14
4XDA	BRAKES, REAR {Meritor 16.5X8.625 CAST PLUS} Air S-Cam Type, Cast Spider, Cast Shoe, Double Anchor Pin, Size 16.5" X 8.625", 38,000-lb Capacity per Axle	0/131	131

<u>Code</u>	<u>Description</u>	<u>F/R Wt</u>	<u>Tot Wt</u>
		(lbs)	(lbs)
4EVH	BRAKE CHAMBERS, REAR AXLE {MGM TR3030LP3TSHD} 30/30 SqIn Spring Brake	0/9	9
4LGA	SLACK ADJUSTERS, REAR {Haldex} Automatic	0/16	16
4LGR	SLACK ADJUSTER PINS Stainless Steel Slack Adjuster Pins/Cotter Pins on Front and Rear	0/0	0
4SPA	AIR COMPRESSOR {Cummins} 18.7 CFM	0/0	0
4EBD	AIR DRYER {Wabco System Saver 1200} with Heater	8/3	11
4VKC	AIR DRYER LOCATION Mounted Inside Left Rail, Back of Cab	14/7	21
4VHZ	AIR TANK LOCATION (2) Mounted Under Cab, Outside Left Rail, on Step Bracket, with Ground Clearance	39/15	54
4722	DRAIN VALVE {Bendix DV-2} Automatic, with Heater, for Air Tank	1/0	1

STEERING

5PTB	STEERING GEAR (2) {Sheppard M100/M80} Dual Power	102/-6	96
5708	STEERING COLUMN Tilting	14/1	15
5CAW	STEERING WHEEL 4-Spoke; 18" Dia., Black	0/0	0

DRIVELINES

6DGG	DRIVELINE SYSTEM {Dana Spicer} 1710, for 4x2/6x2	5/23	28
------	--	------	----

EXHAUST SYSTEMS

7BMB	EXHAUST SYSTEM Horizontal Aftertreatment System, Frame Mounted Right Side Under Cab, for Single Vertical Tail Pipe, Frame Mounted Right Side Back of Cab, for Improved Ground Clearance	131/34	165
7BEV	AFTERTREATMENT COVER Steel, Black	11/2	13
7WDM	EXHAUST HEIGHT 10'	17/11	28
7WDN	MUFFLER/TAIL PIPE GUARD (1) Aluminum	10/6	16
7WZY	SWITCH, FOR EXHAUST 2 Position, Lighted & Latching, On/Off Type, Mounted in IP, Inhibits Diesel Particulate Filter Regeneration as Long as Switch is in On Position	2/0	2
7WAZ	TAIL PIPE (1) Turnback Type	7/3	10

ELECTRICAL SYSTEMS

8000	ELECTRICAL SYSTEM 12-Volt, Standard Equipment	0/0	0
	<u>Includes</u>		
	: DATA LINK CONNECTOR For Vehicle Programming and Diagnostics In Cab		
	: HAZARD SWITCH Push On/Push Off, Located on Instrument Panel to Right of Steering Wheel		
	: HEADLIGHT DIMMER SWITCH Integral with Turn Signal Lever		
	: PARKING LIGHT Integral with Front Turn Signal and Rear Tail Light		
	: STARTER SWITCH Electric, Key Operated		

<u>Code</u>	<u>Description</u>	<u>F/R</u>	<u>Wt</u>	<u>Tot</u>	<u>Wt</u>
			(lbs)		(lbs)
	: STOP, TURN, TAIL & B/U LIGHTS Dual, Rear, Combination with Reflector : TURN SIGNAL SWITCH Self-Cancelling for Trucks, Manual Cancelling for Tractors, with Lane Change Feature : WINDSHIELD WIPER SWITCH 2-Speed with Wash and Intermittent Feature (5 Pre-Set Delays), Integral with Turn Signal Lever : WINDSHIELD WIPERS Single Motor, Electric, Cowl Mounted : WIRING, CHASSIS Color Coded and Continuously Numbered				
12VYL	ACCESSORY WIRING, SPECIAL for Road Speed Wire Coiled Under Instrument Panel for Customer Use		0/0		0
8WXD	ALARM, PARKING BRAKE Electric Horn Sounds in Repetitive Manner When Vehicle Park Brake is "NOT" Set, with Ignition "OFF" and any Door Opened		0/0		0
8GXD	ALTERNATOR {Leece-Neville AVI160P2013} Brush Type, 12 Volt, 160 Amp Capacity, Pad Mount, with Remote Sense		0/0		0
8RPR	ANTENNA for Increased Roof Clearance Applications		1/0		1
8THJ	AUXILIARY HARNESS 3.0' for Auxiliary Front Head Lights and Turn Signals for Front Plow Applications		2/0		2
8WDG	BACK-UP ALARM {Preco 1059} Electronic; Solid State, Dual Function, 112 dBA		0/1		1
8WEK	BATTERY BOX Steel, with Fiberglass Cover, 2-4 Battery Capacity, Mounted Right Side Perpendicular to Frame Rail, 35" Back of Cab		-43/20		-23
8RMH	BATTERY DISCONNECT SWITCH {Cole-Hersee 75920-06} 300 Amp, Disconnects Charging Circuits, Locks with Padlock, Battery Box Mounted		3/0		3
8MSH	BATTERY SYSTEM {Fleetrite} Maintenance-Free, (4) 12-Volt 2640CCA Total, Top Threaded Stud		55/51		106
8HAB	BODY BUILDER WIRING Back of Day Cab at Left Frame or Under Sleeper, Extended or Crew Cab at Left Frame; Includes Sealed Connectors for Tail/Amber Turn/Marker/ Backup/Accessory Power/Ground and Sealed Connector for Stop/Turn		2/0		2
8RGA	2-WAY RADIO Wiring Effects; Wiring with 20 Amp Fuse Protection, Includes Ignition Wire with 5 Amp Fuse, Wire Ends Heat Shrink and Routed to Center of Header Console in Cab		1/0		1
8XAH	CIRCUIT BREAKERS Manual-Reset (Main Panel) SAE Type III with Trip Indicators, Replaces All Fuses		0/0		0
8WPH	CLEARANCE/MARKER LIGHTS (5) {Truck Lite} Amber LED Lights, Flush Mounted on Cab or Sunshade		0/0		0
8HAH	ELECTRIC TRAILER BRAKE/LIGHTS Accommodation Package to Rear of Frame; for Combined Trailer Stop, Tail, Turn, Marker Light Circuits; Includes Electric Trailer Brake Accommodation Package with Cab Connections for Mounting Customer Installed Electric Brake Unit, Less Trailer Socket		0/2		2
8XNY	HEADLIGHTS Halogen		0/0		0
8WRB	HEADLIGHTS ON W/WIPERS Headlights Will Automatically Turn on if Windshield Wipers are turned on		0/0		0

<u>Code</u>	<u>Description</u>	<u>F/R</u>	<u>Wt (lbs)</u>	<u>Tot Wt (lbs)</u>
8HXT	HORN, AIR (2) Single Tone, Chrome, Roof Mounted, with Lanyard Pull Cord	0/0	0	0
8VAY	HORN, ELECTRIC Disc Style	0/0	0	0
8WZP	INDICATOR, BATTERY WARNING Green BATTERY ON Indicator, Mounted on Left Side of Instrument Panel, To be Used with Factory Installed or Customer Mounted Battery Disconnect Switch	1/0	1	1
8WWJ	INDICATOR, LOW COOLANT LEVEL with Audible Alarm	0/0	0	0
8WBW	JUMP START STUD Remote Mounted	2/0	2	2
8XPK	POWER SOURCE, ADDITIONAL Auxiliary Power Outlet (APO) with USB-A Port and USB-C Port, Located in the Instrument Panel	0/0	0	0
8RPS	RADIO AM/FM/WB/Clock/Bluetooth/USB Input/Auxiliary Input	3/0	3	3
8695	SNOW SHIELD (2) Chrome; for Dual Air Horns	2/0	2	2
8RMZ	SPEAKERS (2) 6.5" Dual Cone Mounted in Both Doors, (2) 5.25" Dual Cone Mounted in Both B-Pillars	6/2	8	8
8WTK	STARTING MOTOR {Delco Remy 38MT Type 300} 12 Volt, Less Thermal Over-Crank Protection	8/0	8	8
8WMA	SWITCH, TOGGLE, FOR WORK LIGHT Lighted; on Instrument Panel and Wiring Effects for Customer Furnished Back of Cab Light	2/1	3	3
8WPZ	TEST EXTERIOR LIGHTS Pre-Trip Inspection will Cycle all Exterior Lamps Except Back-up Lights	0/0	0	0
8XJE	TURN SIGNALS, FRONT Dual Face, LED, Amber/Amber, Mounted on Top of Fender, Used with Standard Flush Mounted Front Turn Signal, Side Marker Lamps, Parking Lights and Reflectors	0/0	0	0
8WGL	WINDSHIELD WIPER SPD CONTROL Force Wipers to Slowest Intermittent Speed When Park Brake Set and Wipers Left on for a Predetermined Time	0/0	0	0

FRONT END

9WBC	FRONT END Tilting, Fiberglass, with Three Piece Construction, for WorkStar/HV	0/0	0	0
9585	FENDER EXTENSIONS Rubber	6/0	6	6
9HBM	GRILLE Stationary, Chrome	0/0	0	0
9HBN	INSULATION, SPLASH PANELS for Sound Abatement	2/0	2	2
9HAN	INSULATION, UNDER HOOD for Sound Abatement	10/0	10	10
9AAB	LOGOS EXTERIOR Model Badges	0/0	0	0
9AAE	LOGOS EXTERIOR, ENGINE Badges	0/0	0	0

SPEEDOMETER, TOOLS, MISC

10021	CHASSIS COATING Corrosion Resistant E-Coat Primer Coating for Single Frame Rails	0/0	0	0
10AGB	COMMUNICATIONS MODULE Telematics Device with Over the Air Programming; Includes Five Year Data Plan and International 360	1/0	1	1

<u>Code</u>	<u>Description</u>	<u>F/R Wt</u>	<u>Tot Wt</u>
		(lbs)	(lbs)
10060	PAINT SCHEMATIC, PT-1 Single Color, Design 100	0/0	0
	<u>Includes</u> : PAINT SCHEMATIC ID LETTERS "WL"		
10761	PAINT TYPE Base Coat/Clear Coat, 1-2 Tone	0/0	0
10SLV	PROMOTIONAL PACKAGE Government Silver Package	0/0	0
10WCY	SAFETY TRIANGLES	6/0	6

FUEL TANKS

15SSC	FUEL TANK Temporary, Top Draw, Non-Polished Aluminum, D-Style, 16" Tank Depth, 50 US Gal (189L), Mounted Left Side, Back of Cab	24/2	26
15WDG	DEF TANK 7 US Gal (26L) Capacity, Frame Mounted Outside Left Rail, Under Cab	0/0	0
15LNR	FUEL/WATER SEPARATOR {Racor 400 Series} with Primer Pump, Includes Water-in-Fuel Sensor, Mounted on Engine	0/0	0

WHEELS, TIRES - FRONT

27DPN	WHEELS, FRONT {Accuride 29039} DISC; 22.5x9.00 Rims, Powder Coat Steel, 5-Hand Hole, 10-Stud, 285.75mm BC, Hub-Piloted, Flanged Nut, with Steel Hubs, Non-Standard Offset, with .5" Thick Disc	62/0	62
7682543212	(2) TIRE, FRONT 315/80R22.5 Load Range L XZU-S2 (MICHELIN), 488 rev/mile, 65 MPH, All-Position	64/0	64

WHEELS, TIRES - REAR

28DUK	WHEELS, REAR {Accuride 29169} DUAL DISC; 22.5x8.25 Rims, Powder Coat Steel, 5-Hand Hole, 10-Stud, 285.75mm BC, Hub-Piloted, Flanged Nut, with .472" Thick Increased Capacity Disc and Steel Hubs	0/24	24
7382158102	(4) TIRE, REAR 12R22.5 Load Range H G622 RSD (GOODYEAR), 482 rev/mile, 75 MPH, Drive	0/32	32

BODY INTEGRATION

60AAG	BDY INTG, REMOTE POWER MODULE Mounted Inside Cab Behind Driver Seat, Up to 6 Outputs & 6 Inputs, Max 20 amp per Channel, Max 80 amp Total; Includes 1 Switch Pack with Latched Switches	0/0	0
	Cab schematic 100WL Location 1: 2303, Red (Std) Chassis schematic N/A Services Section:		

WARRANTY

40128	WARRANTY Standard for HV507, HV50B, HV607 Models, Effective with Vehicles Built July 1, 2017 or Later, CTS-2025A	0/0	0
-------	--	-----	---

<u>Code</u>	<u>Description</u>	<u>F/R</u>	<u>Wt</u>	<u>Tot</u>	<u>Wt</u>
		(lbs)	(lbs)	(lbs)	(lbs)
40TWA	SRV CONTRACT, EXT ALLISON XMSN {Allison} To 60-Month/Unlimited Miles/km, for Allison 3500 RDS with Dump Truck or Mixer Vocations (ST01, ST06, ST07)	0/0		0	
	Total Component Weight:	8171	4797	12968	
		(lbs)	(lbs)	(lbs)	(lbs)
		(lbs)	(lbs)	(lbs)	(lbs)
	MiDEAL Fee Spec 3958-0170D	0/0		0	
	Total Goods Purchased:	0/0		0	

The weight calculations included in this proposal are an estimate of future vehicle weight. The actual weight as manufactured may be different from the estimated weight. Navistar, Inc. shall not be liable for any consequences resulting from any differences between the estimated weight of a vehicle and the actual weight.

(0012EYX)

ATTACHMENTS: 0012VXT 0012THT 0007WZY

<u>Parameter</u>	<u>Value</u>	<u>UOM</u>
Max Accelerator Vehicle Speed	65	MPH
Road Speed Governor Upper Droop	3	MPH
Road Speed Governor Lower Droop	0	MPH
Driver Initiated Override (DIO)	N, DISABLE FEATURE OR FUNCTION	N/A
DIO Maximum Road Speed Delta	3	MPH
DIO Maximum Distance	100	MILES
Max Engine Speed No Veh Speed Sensr	2052	RPM
LBSC Enable	N, DISABLE FEATURE OR FUNCTION	N/A
LBSC - Engine Speed Breakpoint	1800	RPM
Gear Down Protection Enable	N, DISABLE FEATURE OR FUNCTION	N/A
GDP - Heavy Load Vehicle Speed	62	MPH
GDP - Light Load Vehicle Speed	57	MPH
Driver Reward Enable	N, DISABLE FEATURE OR FUNCTION	N/A
Driver Reward Mode	0, ROAD SPEED GOVERNOR	N/A
Fuel Economy - Expected Level	7.00	MPG
Fuel Economy - Good Level	7.25	MPG
Fuel Economy - Best Level	7.50	MPG
% Idle Time - Expected Level	30	%
% Idle Time - Good Level	20	%
% Idle Time - Best Level	10	%
Speed Reward - Expected Level	0	MPH
Speed Reward - Good Level	0	MPH
Speed Reward - Best Level	0	MPH
Speed Reward - Penalty Level	0	MPH
Idle Speed Adjustment Enable	Y, ENABLE FEATURE OR FUNCTION	N/A
Low Idle Speed	750	RPM
Idle Shutdown Enable	N, DISABLE FEATURE OR FUNCTION	N/A
ISD Time Before Shutdown	15.0	MIN
ISD Percent Engine Loading	100	%
ISD In PTO	N, DISABLE FEATURE OR FUNCTION	N/A
ISD Manual Override	N, DISABLE FEATURE OR FUNCTION	N/A
ISD With Parking Brake Set	N, DISABLE FEATURE OR FUNCTION	N/A
ISD Ambient Temperature Override	N, DISABLE FEATURE OR FUNCTION	N/A
ISD Cold Ambient Air Temperature	30	F
ISD Intermediate Ambient Air Temp	40	F
ISD Hot Ambient Air Temperature	81	F
ISD Manual Override Inhibit Zone En	N, DISABLE FEATURE OR FUNCTION	N/A
ISD Hot Ambient Automatic Override	Y	N/A
ISD Engine Coolant Temp Threshold	53	F
Cruise Control Enable	Y, ENABLE FEATURE OR FUNCTION	N/A
CC Maximum Vehicle Speed	65	MPH
CC Save Set Speed	N, DISABLE FEATURE OR FUNCTION	N/A
CC Upper Droop	3.0	MPH
CC Lower Droop	0.0	MPH
CC Auto Resume	N, DISABLE FEATURE OR FUNCTION	N/A
CC Engine Brake Swtch Bypass Enable	N, DISABLE FEATURE OR FUNCTION	N/A
Engine Fan Min On Time For AC	30	SEC
Remote Accelerator Enable	N, DISABLE FEATURE OR FUNCTION	N/A
Remote Accelerator Mode	1, REMOTE ACCELERATOR PEDAL OR LEVER WITH TRANS VERIFICATION	N/A
PTO Enable	Y, ENABLE FEATURE OR FUNCTION	N/A
PTO In Cab Mode	Y, ENABLE FEATURE OR FUNCTION	N/A
Remote PTO Enable	N, DISABLE FEATURE OR FUNCTION	N/A
Remote Station PTO Enable	N, DISABLE FEATURE OR FUNCTION	N/A
PTO Max Engine Speed	2200	RPM

PTO Min Engine Speed	750	RPM
PTO Maximum Engine Load	800	LB-FT
PTO Max Vehicle Speed	2	MPH
PTO Accelerator Override	N, DISABLE FEATURE OR FUNCTION	N/A
PTO Accel Override Max Engine Speed	2400	RPM
PTO Clutch Override	N, DISABLE FEATURE OR FUNCTION	N/A
PTO Service Brake Override	Y, ENABLE FEATURE OR FUNCTION	N/A
PTO Parking Brake Interlock Mode	1, PTO PRK BRK INT TYPE SET TO CAB ONLY	N/A
PTO Transmission Neutral Interlock	Y, ENABLE FEATURE OR FUNCTION	N/A
PTO Eng Spd Limit w/VSS Limit	N, DISABLE FEATURE OR FUNCTION	N/A
PTO Ignore Vehicle Speed Sensor	N, DISABLE FEATURE OR FUNCTION	N/A
PTO Resume Switch Speed	925	RPM
PTO Set Switch Speed	850	RPM
PTO Additional Switch Speed	950	RPM
PTO Ramp Rate	250	RPM/SEC
Remote PTO Number of Speed Settings 1		N/A
Remote PTO Speed Setting 1	1000	RPM
Remote PTO Speed Setting 2	1200	RPM
Remote PTO Speed Setting 3	1400	RPM
Remote PTO Speed Setting 4	1400	RPM
Remote PTO Speed Setting 5	1500	RPM
Remote Station PTO Resume Sw Spd	1000	RPM
Remote Station PTO Set Switch Speed	1500	RPM
Remote Station PTO Addition Sw Spd	1500	RPM
Transmission Driven PTO	N, DISABLE FEATURE OR FUNCTION	N/A
Transmission Driven PTO Type	0, ENGINE DRIVEN STEADY LOAD	N/A
Powertrain Protection Enable	N, DISABLE FEATURE OR FUNCTION	N/A
Max Torque Allow By Axle/Driveshaft	23602	LB-FT
Max Torque in Top Gear Range	2995	LB-FT
Max Torque in Int. Gear Range	2995	LB-FT
Max Torque in Low Gear Range	2995	LB-FT
Max Torque w/o Vehicle Speed	1475	LB-FT
Lowest Gear of Top Gear Range	2.00	N/A
Lowest Gear of Int. Gear Range	3.00	N/A
Lowest Gear of Low Gear Range	6.00	N/A
Engine Protection Shutdown	Y, ENABLE FEATURE OR FUNCTION	N/A
Engine Protection Restart Inhibit	Y, ENABLE FEATURE OR FUNCTION	N/A
Engine Prot Coolant Level Shutdown	N, DISABLE FEATURE OR FUNCTION	N/A
Sudden Veh Speed Decel Threshold	6.96	MPH
Trip Information Vehicle Ovrsped1	72	MPH
Trip Information Vehicle Ovrsped2	74	MPH
Veh Speed Sensor Anti Tamper Level	1, HIGH LEVEL	N/A
Maintenance Monitor Enable	N, DISABLE FEATURE OR FUNCTION	N/A
Maintenance Monitor Operating Mode	0, MAINTENANCE MONITOR AUTOMATIC MODE OF OPERATION	N/A
Maintenance Monitor Alert Percent	90	%
Maintenance Monitor Distance	15000	MILES
Maintenance Monitor Fuel	2000	GALLONS
Maintenance Monitor Time	500	HOURS
Maintenance Monitor Interval Factor	1.00	N/A
Master Password	000000	N/A
Adjustment Password	000000	N/A
Reset Password	000000	N/A

These Electronic Parameters have been successfully finalized

(US DOLLAR)

<u>Description</u>	<u>Price</u>
Total Factory List Price Including Options:	\$163,939.00
Total Goods Purchased:	\$957.33
Total Preparation And Delivery:	\$1,760.00
Total Freight:	\$3,100.00
Total Factory List Price Including Freight:	\$169,756.33
Less Customer Allowance:	(\$71,199.31)
Total Vehicle Price:	\$98,557.02
Total Sale Price:	\$98,557.02
Total Per Vehicle Sales Price:	\$98,557.02
Total Net Sales Excluding Taxes:	\$98,557.02
Total License, Title:	\$15.00
Net Sales Price:	\$98,572.02

Note Additional Surcharges may be added by the Manufacturer

Payment for the chassis is due upon delivery of the cab/chassis to the end user or body company; which ever occurs first. If payment is not received in a timely manner additional floorplan(interest) costs may be charged to the end-user customer.

Please make all purchase orders and checks payable to:
Tri-County International Trucks, Inc.
5701 Wyoming Ave.
Dearborn, MI 48126

Please review this proposal very carefully. Your signature below indicates that you accept the specifications and payment terms, contained herein as written and that you are able to approve said specifications for order and payment terms. Please include this proposal number on all correspondence and purchase orders.

Approved by Seller:

Accepted by Purchaser:

Official Title and Date

Firm or Business Name

Authorized Signature

Authorized Signature and Date

TRI COUNTY INTL TRUCKS
3001 E HIGH ST
JACKSON MI 49203
(517)783-2721

This proposal is not binding upon the seller without Seller's Authorized Signature

Official Title and Date

The TOPS FET calculation is an estimate for reference purposes only. The seller or retailer is responsible for calculating and reporting/paying appropriate FET to the IRS.

The limited warranties applicable to the vehicles described herein are Navistar, Inc.'s standard printed warranties which are incorporated herein by reference and to which you have been provided a copy and hereby agree to their terms and conditions.

TRUCK & TRAILER *Specialties, Inc.*

900 Grand Oaks Drive | Howell, MI 48843 | www.ttspec.com | ph: (517) 552-3855 | fx: (517) 552-3666

September 11, 2023

City of Novi
45175 Ten Mile Road, Novi, MI 48375-3024
Attn: Mike Rhatigan, Fleet Asset Manager
HQ0003869

Equipment Quotation

The following pricing is based on City of Rochester Hills RFP-RH-20-023 contract awarded September 2020

Install Monroe 11' model RDS-132-96-56 (Radius Dump Spreader) Body including the following:

Overall length is 132", outside width is 96" and overall side height is 56"
Tailgate height is 50", side height is 44" and 50" at the front
Body shell, head sheet and inner tailgate constructed of 3/16" type 201 stainless steel
Body top rail, corner posts and tailgate supports constructed of 3/16" 201 stainless steel
Body longitudinal is constructed of 1/4" type 201 stainless steel
Auger trough is constructed of type 201 stainless steel
Dual auger discharge with planetary gear boxes
Augers are 7" diameter and step-flighted
Augers include heat-treated, hard-surfaced auger flighting as per specifications
Application rate sensor built into one motor- 100 pulse type
Bolt-on top screens 3/8" rods welded to form 2.5" squares, galvanized
Tailgate is air-operated and includes an air cylinder mounted at the front of the body with latch rods extending to the rear and over center finger latches
Tailgate construction is 3/16" type 201 stainless steel
Tailgate includes a patch gate at the rear
4 oval hole lights in stainless steel light wedges mounted to each rear pillar post
7-gauge type 201 stainless steel single axle fenders mounted integrally to the body
Front and rear grease extension kits for bearings, tailgate cam and hoist trunnions
Install 24" cabshield 10-gauge 201 stainless steel continuously welded to body
Install floor cover constructed of 1/4" AR400 steel
Install body prop kit on each side of the frame
Proximity switch for body-up light
Install Cougar model 3200 DC box vibrator
Install fixed steps on driver-side, front of RDS body with grab handle
Install license plate bracket in upper left corner of tailgate
Install mudflaps fore and aft of rear drive tires

Install Mailhot-type, front-mounted Telescopic Hoist including the following:

Hoist is double-acting
Hoist includes nitrated cylinders
Hoist includes oscillating mounting collar and is trunnion-mounted
Hoist is NTEA class 90

Install Monroe Closed-Loop Pre-Wet System including the following:

NEMA weather-tight fiberglass pump enclosure
Hydraulic driven 7 GPM pump assembly with Dickey-john flow meter
5 PSI in-line check valve for nozzles

TRUCK & TRAILER *Specialties, Inc.*

900 Grand Oaks Drive | Howell, MI 48843 | www.ttspec.com | ph: (517) 552-3855 | fx: (517) 552-3666

3 nozzle w/ brass tips and caps

Twin (2) 75-gallon tanks with stainless steel attaching hardware

Includes crossover tube, bulk fill adapter and flush kit

Remote vent tube for each tank

Install Monroe Rear Spinner Assembly including the following:

Dual, receiver-type tubular mounting

Formed 24" poly spinner disc

Spinner motor includes seal saver

Direction chute on inside of spinner with 3 exterior adjustable deflectors

Construction is type 201 stainless steel

Install grab handles to the Rear Spinner Assembly to aide removal

Install U-shaped stainless steel plate to block salt from being spread into the rear of the truck

Install Roll-Rite Electric Tarp System including the following:

Heavy-duty mesh cover

Aluminum tarp with tension bows and offset elbows

Tarp arms to be mounted to fenders of RDS body

Aluminum wind deflector

Install Monroe Fuel/Oil/Valve Enclosure Combination tank including the following:

100-gallon fuel oil capacity, 35-gallon hydraulic oil capacity (mos. 00166450 & 248896)

Fuel/hydraulic tank/valve enclosure is 7-gauge type 201 stainless steel construction

Hydraulic valve enclosure built into left side of tank

Valve enclosure to have a weather-tight door

Low-oil sensor in hydraulic tank and wired to a low oil shutdown system

Top of the tank Zinga-type, tank-mounted return line filter

Ball valve shutoff on case drain and supply ports

Sight and temperature gauge

Hydraulic tank will be full of AW32 hydraulic oil

"Fuel" and "Hydraulic Oil" stickers shall be installed on the tank

Install 3-step egress & platform from streetside fender to combination reservoir tank

Install fuel hook mounted on tank for safe filling

Step assemblies shall be painted Red

Install Central Hydraulic System including the following:

Force America FASD45L piston pump – 6.0 CID

Front pump mounting bracket

Pump flange

Low-oil shutdown block with override controls

Monroe-type low-oil sender in tank

Spicer drive line with companion flange for easy removal

Valve assembly is Force America Add-a-Fold with the following sections:

4-way EPC section for Hoist with LS relief for down pressure

4-way EPC section for Scraper with LS relief for down pressure

4-way EPC section for Scraper swing

4-way EPC section for Front Plow

4-way EPC section for Front Plow swing

4-way EPC motor-spoiled section for Wing Plow

4-way EPC section for Main Conveyor

3-way EPC section for Pre-wet

3-way EPC section for Rear Spinner

Force America CommandAll Single controller armrest compatible

TRUCK & TRAILER *Specialties, Inc.*

900 Grand Oaks Drive | Howell, MI 48843 | www.ttspec.com | ph: (517) 552-3855 | fx: (517) 552-3666

Above valves mounted within above-frame stainless steel combination tank enclosure
Stainless steel hydraulic couplers for spreader circuit disconnect and plow swing circuit
Return line manifold

All necessary hoses and fittings will be Parker-type

Install Force America Control Center including the following:

Force America CommandAll Single joystick controller with a 6100 model spreader

The electronic controller is a fully proportional, single-stick control that allows for one-handed, finger-tip control of any hydraulic function with six programmable push buttons

The electronic spreader control shall be designed for precise, closed-loop control of granular and pre-wet liquid applications and operate on a CAN Bus protocol

Spreader control interface has two color-coded, continuous rotation encoders, granular & spinner control

The spreader control display shall be a remotely-mounted, 7" diagonal color TFT LCD, with a low-profile 16:9 widescreen format and minimum of 800 x 480 pixel resolution

The operator menus shall be color-coded to match the encoder knobs on the operator interface

A proportional PWM driver and input module (Valve Module) shall be remotely mounted inside the hydraulic valve enclosure for control of both spreader control and joystick control outputs

Truck diagnostic calibration shall be completed prior to delivery

Supply one USB for firmware and storing calibration data

Install PreCise Wireless ARC Temperature Sensor Kit linked to Force America 6100 spreader controller

Air and road temperature sensor mounted on driverside mirror (mo. 1155716)

Sensor cables for connecting to Force America 6100 spreader controller display

Includes mounting, necessary wiring and installation

Install PreCise AVL Monitoring System including the following:

City-supplied Precise unit, tying into proximity switches

City to supply unit and cables for wiring

Install Monroe 34" Husting-type Front Hitch including the following:

12" structural C-channel front bumper with tapered back ends

Double-acting lift cylinder with Socatri rod

Serrated bar steps at the front bumper

Installed roller pins, rollers mounted to hitch frame base

Roller Kit Assembly, hitch-portion

Front tow hooks to be mounted on frame with bumper cut-outs

Two expanded metal front bumper steps driver and passenger side

Expanded metal traction strip placed across the top of the front bumper

Chain box to be mounted on the driver's side of the front bumper

Install Monroe 11' model MP36R11-ISCT Snow Plow including the following:

11' long on top, 36" across

Moldboard painted powder-coat Orange, with the pushframe painted powder-coat Black

Six (6) 1/2" x 4" vertical ribs, 4" x 4" x 3/4" moldboard bottom angle, 2" x 3" x 3/8" moldboard top angle

Moldboard thickness to be 10-gauge

5/8" x 8" x 11' high carbon steel cutting edge with SHS punching

Full-moldboard trip assembly with dual-compression trip

Integral shield style moldboard

Screw-adjustable skid shoes to be mounted on the plow

A rubber snow shield to be mounted across the top of the plow

Blade guides

34" Husting plow-portion hitch

Roller Kit Assembly, plow-portion

Install Monroe 10' model MS4510 Underbody Scraper, two (2) 1' bolt-on extensions including the following:

TRUCK & TRAILER *Specialties, Inc.*

900 Grand Oaks Drive | Howell, MI 48843 | www.ttspec.com | ph: (517) 552-3855 | fx: (517) 552-3666

10' x 20" x 1" moldboard with two (2) 1' bolt-on extensions, one on each end of moldboard

Moldboard is grade 50, hi-tensile steel, not heat-treated

All cylinder rods are Socatri-type, not nitrated

Replaceable trunnions

Piloted centerpin bolt into hangerboard

Grease line kit is included

Cushion valve and j-50 relief valve included

Install proximity switch for scraper position indication

Install 4" grip-strut scraper step, not bar grating, installed raised with step material

Install Ray Stop moldboard protection kit

Install Kennametal single-insert carbide cutting edges

Install two (2) Kennametal D-shaped carbide curbguards one each end of the moldboard

Paint Red bands on ends of moldboard to match cab

Install Monroe model MJW-7' mid-mounted 7' Jr. Wing; parallelogram-type wing including the following:

7' moldboard length, 27" intake height, 28" discharge height

Moldboard is powder-coated Orange

Safety chain shall be installed for transport at any adjusted angle

Wing Post is mounted just ahead of front drive tire with rear push arm mounted behind the rear drive tire

Wing Post is parallelogram design and shall mount directly ahead of the drive tire

Rear pusharm is to be equipped with a 6" cushion spring

Rear pusharms have bolt-in design with grease zerks for ease of maintenance

Front arm banjo plate has captive design

Cylinder includes decel, 4"

Hydraulic circuit for the wing is equipped with a sequencing valve for proper operation of the wing

Sequencing valve shall have built-in, manually adjustable flow controls

Wing is to be equipped with stainless steel hydraulic disconnects for easy removal

Wing will also be equipped with a cushioned rubber stop to prevent it from hitting the body when

placed in the stored position at any adjusted angle

Install two (2) single-hole stainless steel light boxes mounted on the end of the wing, with a Green 6"

oval flasher and an Amber 6" oval flasher and an LED marker light front-facing

Install recycled tire cutting edge 5" x 10" x 83" including a weld-on 2' round stock curbguard

Install two (2) Monroe wing shoes, one each at toe and heel of tire cutting edge

Install double-reinforced 1/2" thick rubber snow deflector

Install proximity switch for wing position indication

Install safety clamp for wing push-arm spring

Install LaserLine model GL3000PMC Wing Plow Guidance Laser including the following:

Green "ultra-bright" laser assembly enclosed in weatherproof housing

Heated front window lens to reduce or eliminate icing

Pneumatic air blast mechanism for lens, blasting every 5 seconds

Control switch installed in-cab for laser on/off and air blast on/off, mounted on backwall of cab

Laser assembly installed on roof of cab

Install Custom Lighting & Electrical including the following:

Four-hole rear wedge stainless steel light boxes with LED lights on rear pillars including:

Driver-side 4-hole wedge on RDS body going down:

Star Green, SoundOff STT, SoundOff Backup & Star Amber

Pass-side 4-hole wedge on RDS body going down:

Star Amber, SoundOff STT, SoundOff Backup & Star Green

Flashers hooked up to wig-wag corner-to-corner

Two (2) SoundOff LED mPower (mo. EMPS20V38-P) amber/green flashers front-facing, under cabshield

TRUCK & TRAILER *Specialties, Inc.*

900 Grand Oaks Drive | Howell, MI 48843 | www.ttspec.com | ph: (517) 552-3855 | fx: (517) 552-3666

Two (2) SoundOff LED mPower (mo. EMPS20V38-P) amber/green flashers side-facing, one per body side

Two (2) Maxxima LED flood lights mounted at rear, angled toward pavement for spreader

Two (2) Maxxima LED flood lights mounted above scraper on left and right side

One (1) Maxxima LED flood light mounted on RDS body to illuminate wing plow

LED button marker lights on the combination body's light wedges

Plow lights and aluminum plow light brackets mounted on hood

Betts junction box and related wiring

Install Preco 1040 back-up alarm

Controls & Switches including the following:

OEM chassis and InPower switches shall control the emergency & work lighting

Chassis switches for the following:

Scraper work lights

Spreader work lights

Wing work light

Spare

Spare

Air-tailgate

Console switches for the following:

Tarp in/out

Camera Air

Vibrator

Force America CommandAll programmable switch assembly installed for the following:

Low-oil pump override

Front flashers

Rear flashers

Side flashers

Spreader on/off

Install Flaming River Electrical Disconnect including the following:

6-minute timed delay switch mounted in-cab

Enclosure with LED indicator mounted at bottom of hydraulic tank

Install Rearview Camera with Wash System including the following:

System tying into chassis wiper fluid reservoir

Chassis wiper controls for activating wash system, momentary in-cab switch for air puffer

Air puffer & washer fluid tubing

CEC34L1 main cable for monitor

MSF5000 stainless steel camera box

VCMS24B color camera, recess-mounted into rear tailgate frame

VOM719WP 7" LCD color monitor

VOSHD6MNT LCD monitor mount

Install ¾" Rear Hitch Plate including the following:

PH-20 pintle hook with multi-drill mounting holes for adjustment height (mounted at 22" to cradle)

Two (2) ¾" D-rings welded on each side for tow chains

The rear hitch shall have support bracing welded for extra strength and stability

Rear tow hooks mounted outside of frame rails

Electric plug 7-way round pin

Install Electric Brake Controller, mounted in dash cubby hole

Install One (1) pry bar tube holder, include rubber bumper inside tube to prevent rattling

Install One (1) spade holder mounted to RDS curbside bulkhead

Install Fire Extinguisher and Triangle Kit

TRUCK & TRAILER *Specialties, Inc.*

900 Grand Oaks Drive | Howell, MI 48843 | www.ttspec.com | ph: (517) 552-3855 | fx: (517) 552-3666

- Install Rustproof top of floor in-cab, remove floor mat and install rustproofing**
- Install Minimizer Floor Mats for International HV607 (mo. FKINTL3B-MIN / 10002433)**
- Install Leaf Spring Block on curbside rear for wing support**

Above installed, non-stainless steel painted price: \$202,215.00 ea.

Chassis requirements to be confirmed prior to order entry:

- CA: 120"
- 6-pack of chassis switches
- Delete OEM bumper
- Front frame extension
- Front of engine PTO
- Stationary grille
- Highest ground clearance package
- Horizontal DPF mounted under the curbside door or behind cab
- Right side with a vertical tailpipe
- Trailer wiring to the rear for electric brake controller
- Temporary fuel tank

Payment Terms: Net 30. Pricing effective for 30 days.

FOB: City of Novi

Delivery: 420-450 days ARO, depending on chassis arrival

Thank you for the opportunity to quote.

Respectfully submitted by,
Jon Luea/Brian Bouwman