

Working, Robin

From: William Lutz [wlutz@signgraphix.net]
Sent: Wednesday, July 30, 2008 5:04 PM
To: Working, Robin
Subject: ZBA Cases

Robin,
Here are the fundamental issues involving clients that we are representing on the August 12th agenda.

Cooper Standard Office Building
39550 Orchard Hill Place

The proposed six(6) sq. ft. sign is virtually invisible from the public right-of-way given the setback and the dense landscaping. This sign will replace the existing "entrance" letters and will create a more architecturally pleasing entryway into the building.

Hino Truck Office Building
41180 Bridge Street

The proposed seventy-five(75) sq. ft. wall sign will be the only identification for this building and will only be visible from the I-96 ramp to I-275. Considering the limited visibility due to the adjacent trees as well as the vehicle speed of the viewing public, this is an appropriate size sign for this location.

Robin, let me know if this is adequate.

Bill Lutz
SignGraphix, inc.
248-848-1700 phone
248-848-1722 fax
wlutz@SignGraphix.net
www.SignGraphix.net

75
Sq. Ft.



Photo
Sketch

SIGNgraphix

39255 Country Club Drive, Suite B-35,
Farmington Hills, Michigan 48331-3490
Ph. 248-848-1700 Fax 248-848-1722
www.signgraphix.net

HINO Trucks

DRAWING: 4-18-08
13600.1 6-06-08
JOB: 6-17-08
16181

41180 Bridge Novi, MI 48375

CLIENT SIGNATURE:

DATE:

These designs, details and plans represented herein are the property of SignGraphix, Inc; specifically developed for your personal use in connection with the project being planned for you by SignGraphix, Inc. It is not to be shown to anyone outside your organization, nor is it to be used, reproduced, exhibited or copied in any fashion whatsoever all any part of this design (excepting registered trademarks) remain the property of SignGraphix, Inc.

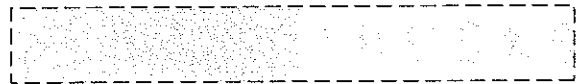

Night Simulation

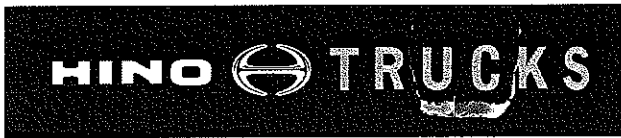

75 Sq. Ft.

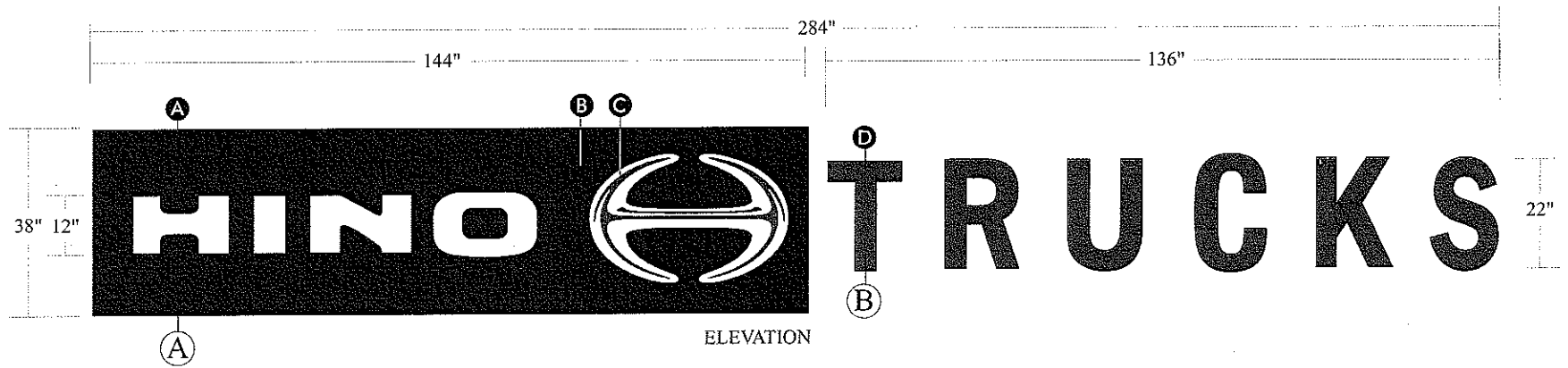

CABINET:
 SignComp Single Face Body (#2025),
 SignComp Tension frame (#2085),
 SignComp Bleed Tension Framce Cover (#2095),
 aluminum backer, 3M Panaflex polyurethane
 flexible sign face. Cabinet and face painted and
 decorated as indicated.

ELECTRICAL:
 Sign to hinge open. Internally illuminated as required,
 120 volt. Disconnect switch to be located on side of
 cabinet. Sign is mounted to wall with concealed fasteners.

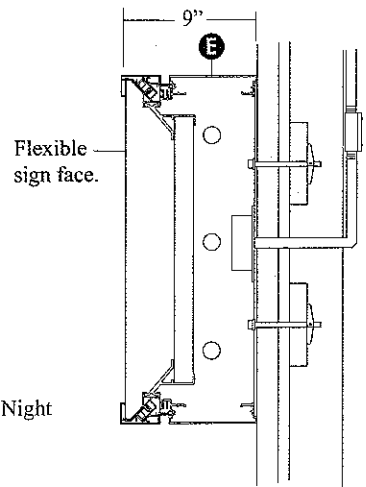

(A) DETAIL THRU SIGN

LETTERS:
 22" high aluminum channel letters, .063"
 sidewalls and backs, 5" deep, painted MAP as
 indicated. 1" Black trimcap welded to 1/8" clear
 acrylic faces with surface applied 3M #3635-91
 Day / Night Smoke Grey vinyl.

ILLUMINATION:
 Letters to be internally illuminated with Sloan
 White LED's. LED transformers mounted in
 metal box behind wall. 120 volt.

INSTALLATION:
 Letters mounted flush to wall as required.

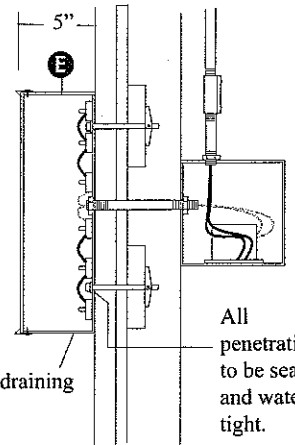

(B) DETAIL THRU LETTERS

Weep holes for draining condensation.

- (A) 3M #3630-73 Dark Red
- (B) 3M #3630-12 Black
- (C) 3M #3630-31 Medium Grey
- (D) 3M #3635-91 Day / Night Film, Smoke Grey
- (E) MAP Black

ONE (1) SIGN INTERNALLY ILLUMINATED CABINET AND ONE (1) SET OF INTERNALLY ILLUMINATED LETTERS
 Scale: 3/8" = 1'-0"

SIGNgraphix

39255 Country Club Drive, Suite B-35,
 Farmington Hills, Michigan 48331-3490
 Ph. 248-848-1700 Fax 248-848-1722
 www.signgraphix.net

HINO Trucks

DRAWING: 4-18-08
 13600 6-06-08
 JOB: 6-17-08
 16181

41180 Bridge Novi, MI 48375

CLIENT SIGNATURE:

DATE:

These designs, details and plans represented herein are the property of SignGraphix, Inc; specifically developed for your personal use in connection with the project being planned for you by SignGraphix, Inc. It is not to be shown to anyone outside your organization, nor is it to be used, reproduced, exhibited or copied in any fashion whatsoever all any part of this design (excepting registered trademarks) remain the property of SignGraphix, Inc.

Hino Trucks

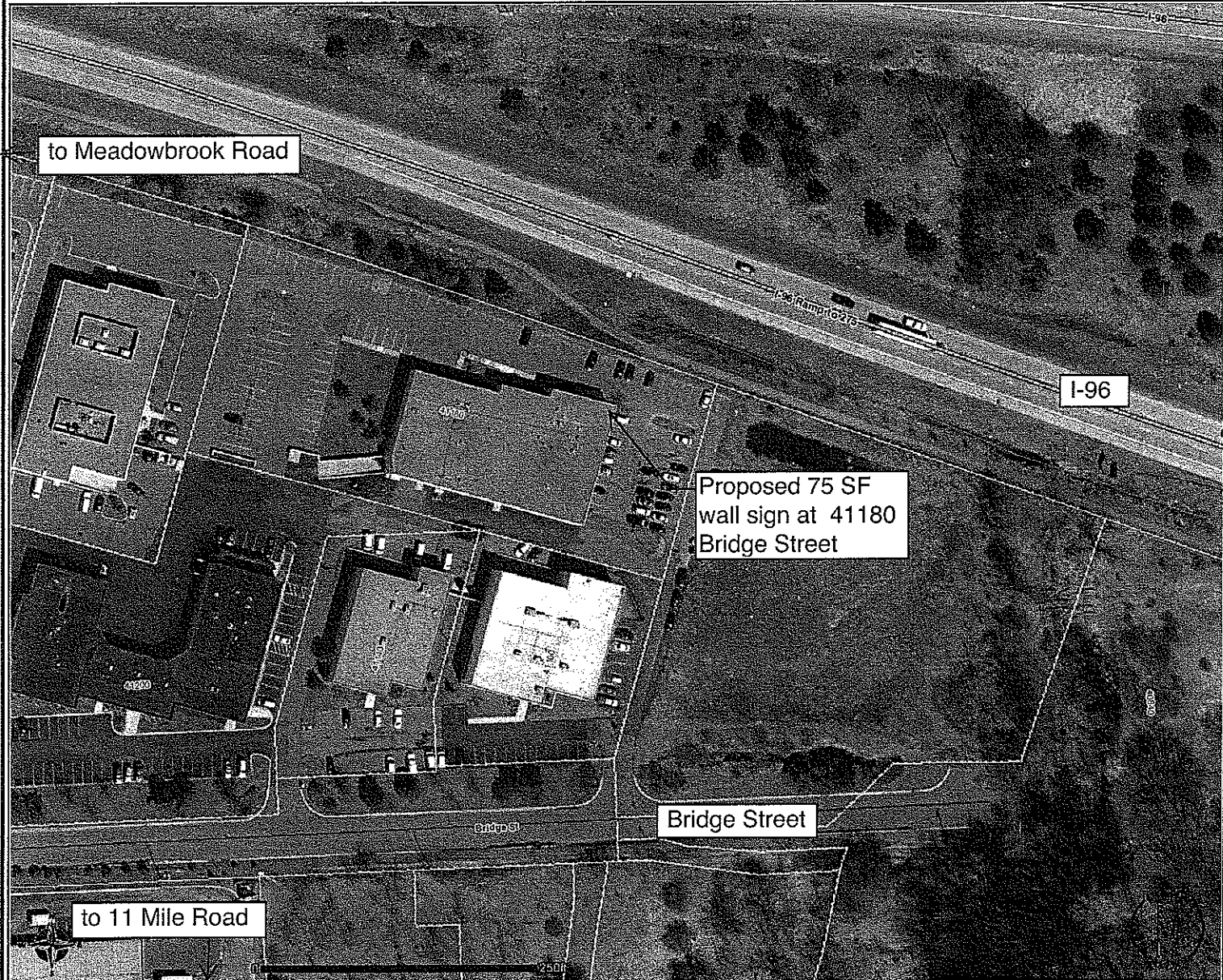

- City Boundary
- Landmarks
- Civic Center
- Rock Financial Showplace
- Court
- DPW
- Fire Station
- Hospital
- Ice Arena
- Library
- Parks & Rec Field Office
- Police Station
- Post Office
- Recycling
- School
- Senior Center
- Railroad
- Roads
- Freeway
- Arterials
- Collectors
- Scenic Drive Road
- Local Roads
- Water - Lakes
- Water - Rivers
- Parcels
- Lots
- Parks
- 2006 Aerial Photos

DISCLAIMER: The information provided herewith has been compiled from recorded deeds, plats, tax maps, surveys, and other public records. The information presented is not a legally recorded map or survey and is not intended as a substitute for original or official source information. The City of Novi makes no warranty, express or implied, as to the accuracy, completeness, or usefulness of the information presented.
 SOURCES: City of Novi, Oakland County, Plansight LLC; October 2006 for County Data; October 2006 for City Data; Aerial Imagery as specified