



CITY of NOVI CITY COUNCIL

Agenda Item D
September 10, 2012

SUBJECT: Approval to award a construction contract for the Village Wood Lake Park Improvements project to PAVEX Corporation, the low bidder, in the amount of \$30,088.

SUBMITTING DEPARTMENT: Department of Public Services, Engineering Division ^{Rev} *BIC*
 Parks, Recreation and Cultural Services

CITY MANAGER APPROVAL: 

EXPENDITURE REQUIRED	\$ 30,088
AMOUNT BUDGETED	\$ 0
APPROPRIATION REQUIRED	\$64,580 (Rollover from FY2011-12 on budget amendment)
LINE ITEM NUMBER	208-691.00-974.300

BACKGROUND INFORMATION:

In 2005, the City received a Michigan Natural Resources Trust Fund Grant for the acquisition of the parcel on the north side of Village Wood Lake east of Meadowbrook Road, as well as the parcel north of Chattman Drive west of Meadowbrook Road. The City subsequently designated both parcels as park land, and named the east parcel Village Wood Lake Park. The grant contemplated that upon acquisition, the Village Wood Lake parcel would be improved so that the park would be accessible to visitors. Staff developed a plan and met with residents in early 2012 on the final plan that is attached and proposed for construction.

The project was included in the FY11-12 budget and includes the construction of an asphalt parking lot at the west end of Village Wood Road and a crushed limestone pathway. The alignment of the proposed pathway is attached for reference. In order to minimize costs, the design and bidding of the project was completed in-house by Engineering staff. It is also proposed that the construction phase engineering will also be completed by Engineering staff.

Five (5) bids were received and opened on August 22, 2012 following a public bid solicitation period. The lowest bidder is PAVEX Corporation. PAVEX's bid is recommended as being in the best interest of the City as it is responsive (i.e., PAVEX has complied with all requirements of the bidding instructions) and is the lowest price. A summary of the five bids is as follows:

Bidder	Bid Total
PAVEX Corporation	\$30,088.01
Arch Construction Inc.	\$30,766.89
Nagle Paving Company	\$33,767.11
Commerce Construction & Landscaping	\$35,060.00
San Marino Excavating	\$38,290.00

Construction is scheduled to begin in late September 2012 and completion is anticipated by November 2012.

RECOMMENDED ACTION: Approval to award a construction contract for the Village Wood Lake Park Improvements project to PAVEX Corporation, the low bidder, in the amount of \$30,088.

	1	2	Y	N
Mayor Gatt				
Mayor Pro Tem Staudt				
Council Member Casey				
Council Member Fischer				

	1	2	Y	N
Council Member Margolis				
Council Member Mutch				
Council Member Wrobel				

VILLAGE WOOD LAKE PARK

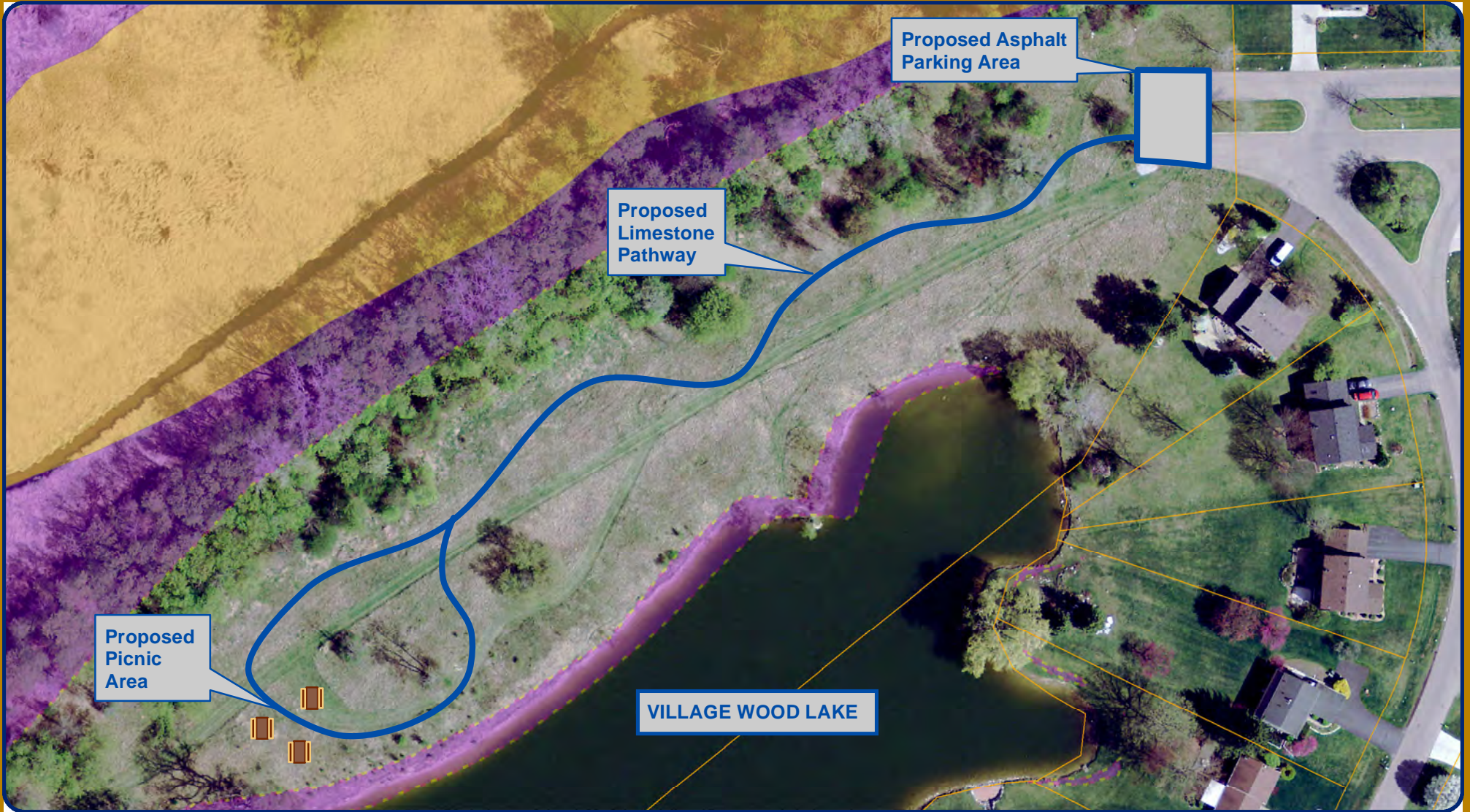



Map Author: Erica Morgan
 Date: 04/16/2012
 Project: Village Wood Lake Park
 Version #: 2

Amended By:
 Date:
 Department:

MAP INTERPRETATION NOTICE

Map information depicted is not intended to replace or substitute for any official or primary source. This map was intended to meet National Map Accuracy Standards and use the most recent, accurate sources available to the people of the City of Novi. Boundary measurements and area calculations are approximate and should not be construed as survey measurements performed by a licensed Michigan Surveyor as defined in Michigan Public Act 132 of 1970 as amended. Please contact the City GIS Manager to confirm source and accuracy information related to this map.

Map Legend

-  FLOODWAY
-  Wetlands
-  Novi Tax Parcel BSA



City of Novi
 Engineering Division
 Department of Public Services
 26300 Delwal Drive
 Novi, MI 48375
cityofnovi.org

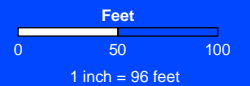

MEMORANDUM



TO: BRIAN COBURN PE, ENGINEERING MANAGER
FROM: ERICA MORGAN, ENGINEERING INTERN
SUBJECT: BID EVALUATION – VILLAGE WOOD LAKE PARK
DATE: AUGUST 27, 2012

On August 22, 2012 at 2:00pm construction bids were opened and publicly read aloud at the City of Novi Civic Center for the Village Wood Lake Park Improvements project.

The City Clerk's office received five (5) sealed bids for this project. PAVEX Corporation submitted the lowest bid. In addition, references were checked and representatives from past projects were contacted. All were very complimentary of the work PAVEX had completed for them.

We therefore recommend that the bid submitted by PAVEX Corporation to be the lowest responsible bid received and further, that they be awarded the construction contract for the total contract amount of \$30,088.01.



Bid Tabulations For
Village Wood Lake Park

No.	Description	Unit	Quantity	PAVEX CORPORATION		ARCH CONSTRUCTION		NAGLE PAVING CO.		COMMERCE CONSTRUCTION		SAN MARINO EXCAVATING	
				Unit Price	Total	Unit Price	Total	Unit Price	Total	Unit Price	Total	Unit Price	Total
1	Soil Erosion Control, Silt Fence	LF	1350	\$ 0.85	\$ 1,147.50	\$ 1.25	\$ 1,687.50	\$ 2.00	\$ 2,700.00	\$ 1.00	\$ 1,350.00	\$ 2.00	\$ 2,700.00
2	Pathway Grading	LF	1100	\$ 7.25	\$ 7,975.00	\$ 3.45	\$ 3,795.00	\$ 8.00	\$ 8,800.00	\$ 10.00	\$ 11,000.00	\$ 12.85	\$ 14,135.00
3	8-Foot Wide 21AA Crushed Limestone Pathway (8")	SY	1124	\$ 8.08	\$ 9,085.51	\$ 11.00	\$ 12,368.89	\$ 9.70	\$ 10,907.11	\$ 9.00	\$ 10,120.00	\$ 6.75	\$ 7,590.00
4	Tree Removal	EA	1	\$ 1,350.00	\$ 1,350.00	\$ 299.50	\$ 299.50	\$ 500.00	\$ 500.00	\$ 700.00	\$ 700.00	\$ 500.00	\$ 500.00
5	Concrete Curb and Gutter Removal	LF	70	\$ 6.00	\$ 420.00	\$ 11.00	\$ 770.00	\$ 8.00	\$ 560.00	\$ 15.00	\$ 1,050.00	\$ 12.00	\$ 840.00
6	HMA Pavement (4" HMA on 8" 21AA)	SY	100	\$ 44.40	\$ 4,440.00	\$ 60.00	\$ 6,000.00	\$ 42.00	\$ 4,200.00	\$ 45.00	\$ 4,500.00	\$ 49.00	\$ 4,900.00
7	Concrete Curb and Gutter (6 1/2" W x 4" H)	LF	30	\$ 40.00	\$ 1,200.00	\$ 34.50	\$ 1,035.00	\$ 25.00	\$ 750.00	\$ 35.50	\$ 1,065.00	\$ 50.00	\$ 1,500.00
8	Parking Lot Striping	LSUM	1	\$ 300.00	\$ 300.00	\$ 920.00	\$ 920.00	\$ 400.00	\$ 400.00	\$ 300.00	\$ 300.00	\$ 275.00	\$ 275.00
9	Concrete Parking Blocks	EA	6	\$ 50.00	\$ 300.00	\$ 103.50	\$ 621.00	\$ 75.00	\$ 450.00	\$ 75.00	\$ 450.00	\$ 50.00	\$ 300.00
10	Restoration	LSUM	1	\$ 2,520.00	\$ 2,520.00	\$ 2,070.00	\$ 2,070.00	\$ 3,000.00	\$ 3,000.00	\$ 2,925.00	\$ 2,925.00	\$ 3,900.00	\$ 3,900.00
11	Mobilization (5% Max)	LSUM	1	\$ 1,350.00	\$ 1,350.00	\$ 1,200.00	\$ 1,200.00	\$ 1,500.00	\$ 1,500.00	\$ 1,600.00	\$ 1,600.00	\$ 1,650.00	\$ 1,650.00
CONSTRUCTION TOTAL				\$ 30,088.01		\$ 30,766.89		\$ 33,767.11		\$ 35,060.00		\$ 38,290.00	

2/23/2012

To: Mayor and City Council members
FYI on progress to meet grant obligations.
Clay



MEMORANDUM

TO: CLAY PEARSON, CITY MANAGER
VICTOR CARDENAS, ASSISTANT CITY MANAGER

FROM: JASON S. MANGUM, DIRECTOR, PARKS, RECREATION AND CULTURAL SERVICES

SUBJECT: VILLAGE WOOD LAKE MEETING

DATE: FEBRUARY 21, 2012

The PRCS Department will be holding another informational meeting regarding the improvements to be made at Village Wood Lake Park. The meeting is being scheduled based on feedback received from the previous meeting in June to discuss the parking improvements and trail enhancements to the park. These enhancements are required by the Department of Natural Resources (DNR) grant guideline to make the property accessible. The improvements will provide the best combination of natural resource protection and recreational opportunities for the public and provide public access to the property for new recreation opportunities.

Estimated costs for the project will be \$64,579 and is included in the current PRCS budget for FY 2011-2012. Improvements at this time are only for the portion of the park located East of Meadowbrook Road, and do not include any portion of the 9 ½ mile trail as outlined in the Non-Motorized Master Plan. Engineering is currently working on developing a cost estimate to determine the possibility of incorporating a portion of that trail into this project.

The meeting will be held at 7pm on Monday, March 5, 2012 in the Novi Civic Center Council Chambers. Notification of this meeting was sent to residents in the immediate area being affected by the improvements to the east side of Village Wood Lake Park. Resident questions and comments will be addressed by Aaron Staup, City Construction Engineering Coordinator, and myself.

VILLAGE WOOD LAKE PARK

Proposed Parking Lot

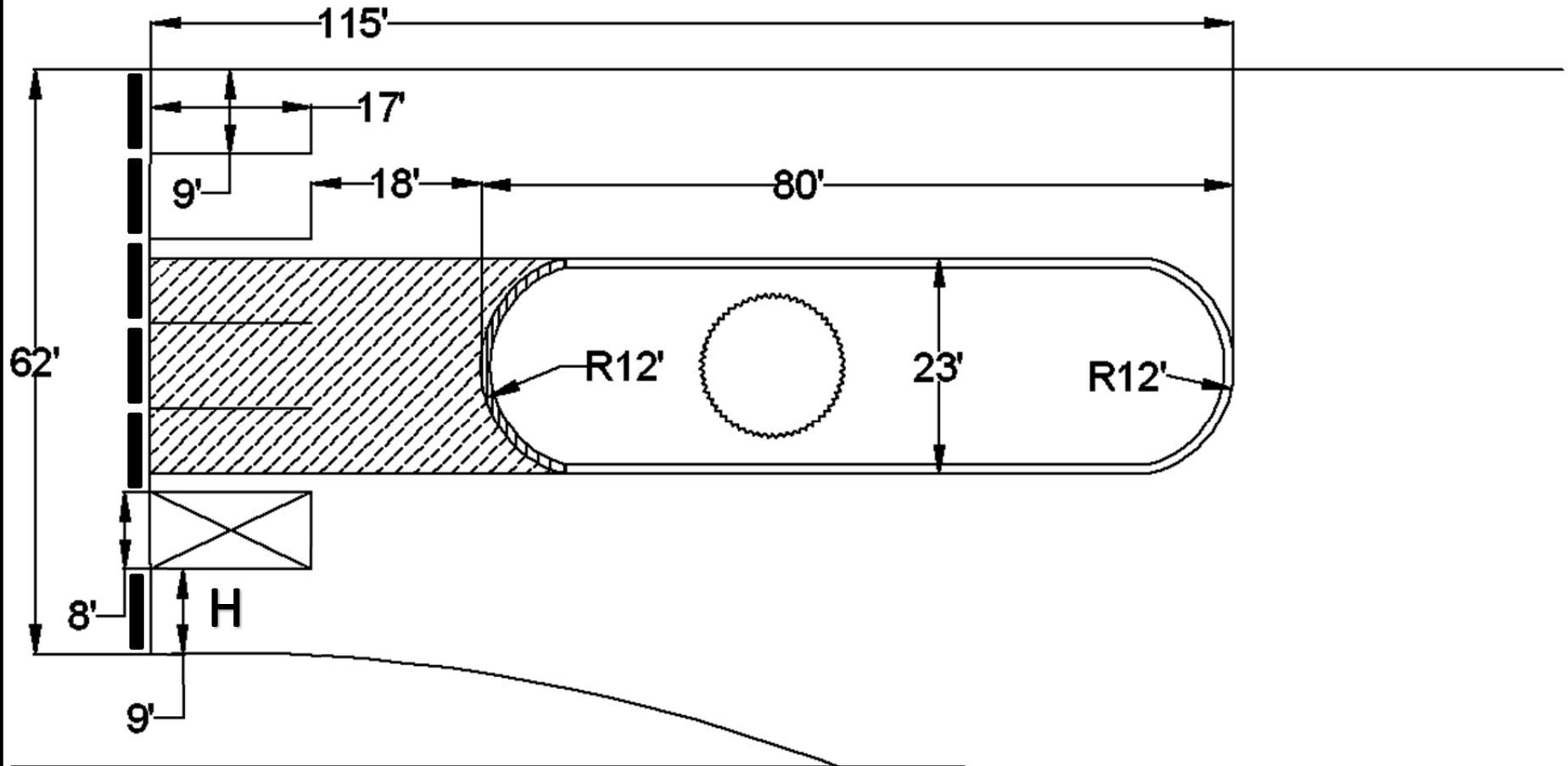

LEGEND:



Proposed Pavement



Parking Blocks

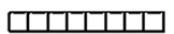

Proposed Curb

Project: Village Wood Lake Park

Drawn By: Erica Morgan

Date: July 21, 2011

Page: 3 of 3

